

INFORMATION

PRODUCT No. : X1E004501003000

MODEL : SG7050CCN

INFO. No. : A14-1089-0A

DATE : Nov. 17. 2014

SEIKO EPSON CORPORATION

**8548 Naka-minowa
Minowa-machi Kamiina-gun
Nagano-ken
399-4696 Japan**

INTRODUCTION

1. The contents is subject to change without notice.
Please exchange the specification sheets regarding the product's warranty.
2. This sheet is not intended to guarantee or provide an approval of implementation of industrial patents.
3. We have prepared this sheet as carefully as possible.
If you find it incomplete or unsatisfactory in any respect, We would welcome your comments.

This product is compliant with RoHS Directive.

This Product supplied (and any technical information furnished, if any) by Seiko Epson Corporation shall not be used for the development and manufacture of weapon of mass destruction or for other military purposes. Making available such products and technology to any third party who may use such products or technologies for the said purposes are also prohibited.

This product listed here is designed as components or parts for electronics equipment in general consumer use. We do not expect that any of these products would be incorporated or otherwise used as a component or part for the equipment, which requires an extra high reliability, such as satellite, rocket and other space systems, and medical equipment, the functional purpose of which is to keep life.

Product No. / Model

The product No. of this crystal oscillator unit is X1G004501003000.

The model is SG7050CCN.

Suffix : HJGA

Contents

Item No.	Item	Page
[1]	Absolute maximum ratings	2
[2]	Operating range	2
[3]	Frequency characteristics	2
[4]	Terminal assignment	3
[5]	Electrical characteristics	4
[6]	Test circuit	5
[7]	Timing chart	6-7
[8]	Environmental and mechanical characteristics	8
[9]	Electro static Discharge	9
[10]	Dimensions and marking layout	10
[11]	Notes	11
[12]	Recommendable patterning	12

[1] Absolute maximum ratings

Parameter	Symbol	Value	Unit	Note
Supply voltage	V _{CC} -GND	-0.3 to +7.0	V	
Storage temperature *	T _{stg}	-40 to +100	°C	Stored as bare product after unpacking.
Input voltage	V _{IN}	-0.5 to V _{CC} +0.5	V	OE Terminal

* Concerning the frequency change, please refer [8] Environmental and mechanical characteristics.

[2] Operating range

Parameter	Symbol	Value			Unit	Note
		Min.	Typ.	Max.		
Supply voltage	V _{CC}	4.5	5.0	5.5	V	Symbol : H
Supply voltage	GND	0.0	0.0	0.0	V	
Input voltage	V _{IN}	GND	-	V _{CC}	V	
Operating temperature	T _{use}	-40	+25	+85	°C	Symbol : G
Output load condition	L _{CMOS}	-	-	50	pF	

- Start up time(0 %V_{CC}→90 %V_{CC}) of power source should be more than 150 μs.
- By-pass capacitor (0.01 μF to 0.1 μF) is connected near V_{CC} between V_{CC} and GND.
(Refer to [11] Recommendable patterning)

[3] Frequency characteristics

Output frequency (f₀) 3.072 MHz

Parameter	Symbol	Value[1 × 10 ⁻⁶]	Note
Frequency tolerance *	f _{tol} (OSC)	± 50	Symbol : J
Aging	f _{aging}	± 5	T _{use} =+25 °C, V _{CC} =3.3 V First year

* This includes initial frequency tolerance, temperature characteristics, input voltage characteristics, and load characteristics, but excludes aging.

[4] Terminal assignment

Top View

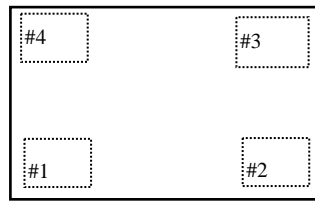

Terminal name	Terminal No.	Terminal type.
OE	1	INPUT
GND	2	—
OUT	3	OUTPUT
Vcc	4	—

OE pin : High or open → Specified frequency output = enable
OE pin : Low → Output is high impedance = disabled

* When the OE terminal is not controlled, it should be connected to the Vcc terminal.

[5] Electrical characteristics

(Please see page 2 [2] Operating range)

Parameter	Symbol	Value		Unit	Note
		Min.	Max.		
Start up time	tosc	-	4	ms	t=0 at 90 %Vcc
Current consumption	I _{CC}	-	20	mA	No load
Disable current	I _{oe}	-	10	mA	OE=GND
Output rise time *1	tr	-	5.0	ns	20 %Vcc → 80 %Vcc CMOS load 0.4V to 2.4V Level TTL load
		-	5.0		
Output fall time *1	tf	-	5.0	ns	80 %Vcc → 20 %Vcc CMOS load 2.4V to 0.4V Level TTL load
		-	5.0		
Symmetry	SYM	40	60	%	50 %Vcc Level CMOS load 1.4V Level TTL load
		45	55		
High level output voltage	V _{OH}	V _{CC} -0.4	-	V	I _{OH} = -8 mA
Low level output voltage	V _{OL}	-	0.4	V	I _{OL} = 16 mA
High level input voltage	V _{IH}	2.0	-	V	OE terminal
Low level input voltage	V _{IL}	-	0.8	V	OE terminal
Input current	I _{IH}	-	1.0	μA	V _{IN} = V _{CC}
	I _{IL}	-100	-	μA	V _{IN} = GND
Output disable time *2	t _{stp}	-	100	ns	OE terminal High → Low
Output enable time *2	t _{sta}	-	100	ns	OE terminal Low → High

Refer to *1 [6] Test circuit *2 [7] Timing chart

◆Reference : Current consumption Typ. value (V_{DD} = 5.0V , T_a = +25°C , No load)

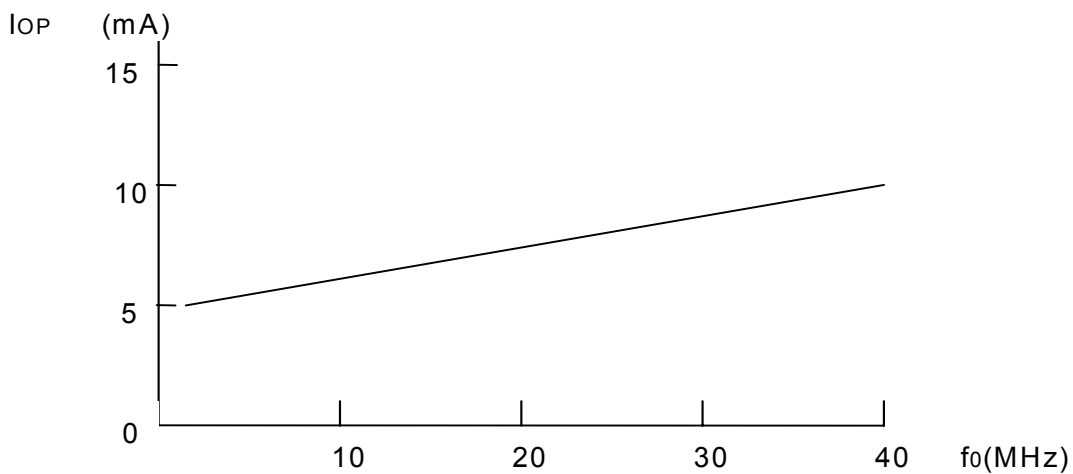

[6] Test circuit

1) Waveform observation

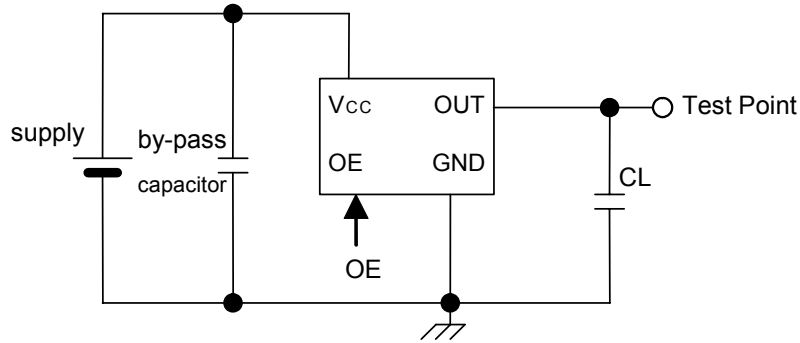

2) TTL load: 10 TTL

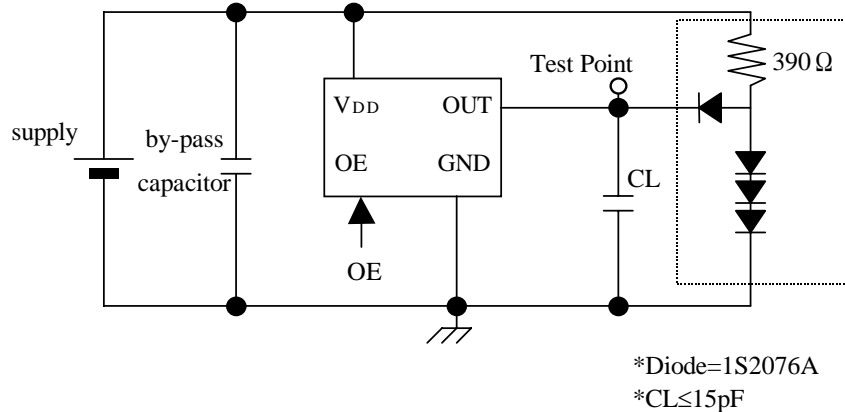

3) Current consumption

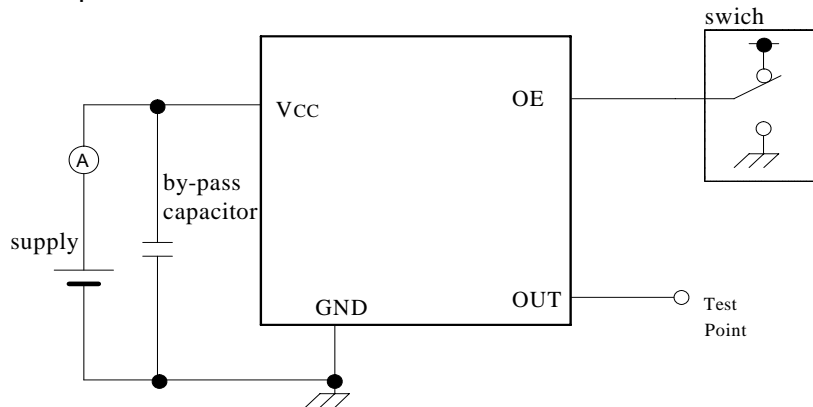

*Current consumption under the disable function should be OE= GND.

4) Condition

(1) Oscilloscope

- Band width should be minimum 5 times higher (wider) than measurement frequency.
- Probe earth should be placed closely from test point and lead length should be as short as possible.
- * Recommendable to use miniature socket. (Don't use earth lead.)

(2) L_CMOS also includes probe capacitance.

(3) By-pass capacitor (0.01 μ F to 0.1 μ F) is placed closely between Vcc and GND.

(4) Use the current meter whose internal impedance value is small.

(5) Power supply

- Start up time (0 %V_{CC} → 90 %V_{CC}) of power source should be more than 150 μ s.
- Impedance of power supply should be as lowest as possible.

[7] Timing chart

1) C-MOS load

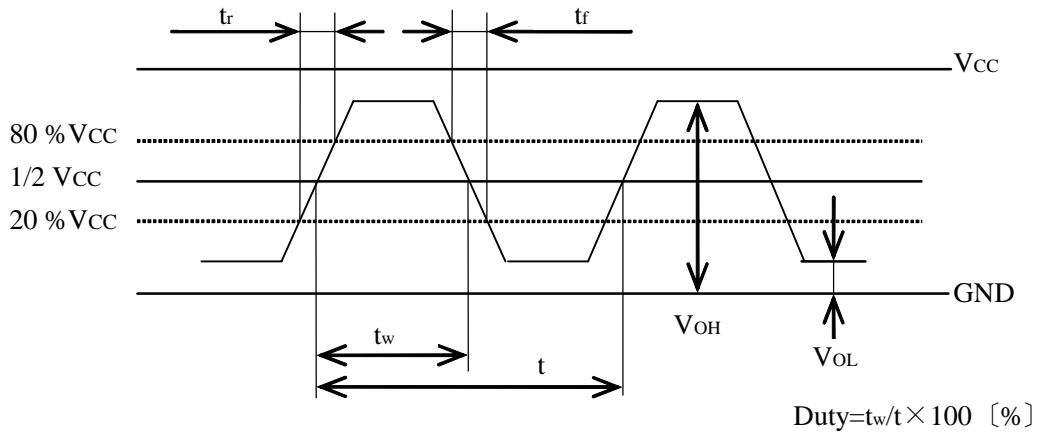

2) TTL load (TTL Level)

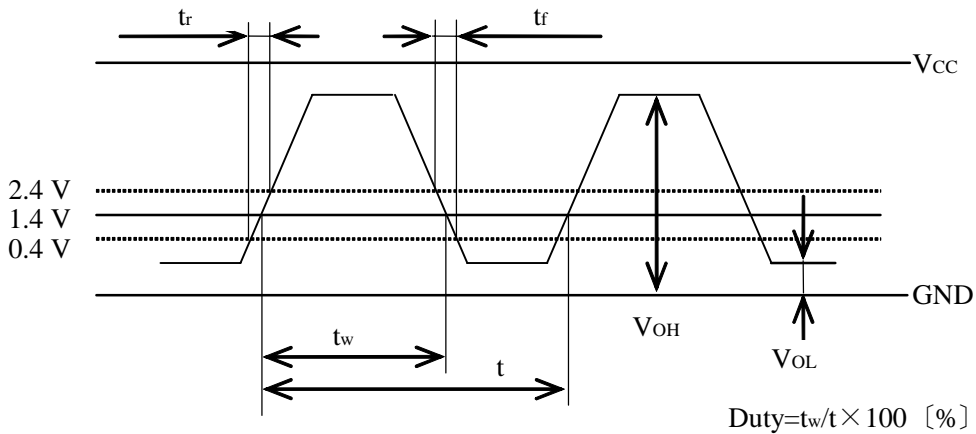

3) OE function and timing

OE function	Osc. circuit	Output status
High or Open	Oscillation	Specified frequency is output : Enable
Low	Oscillation stop	Output becomes high impedance : Disable

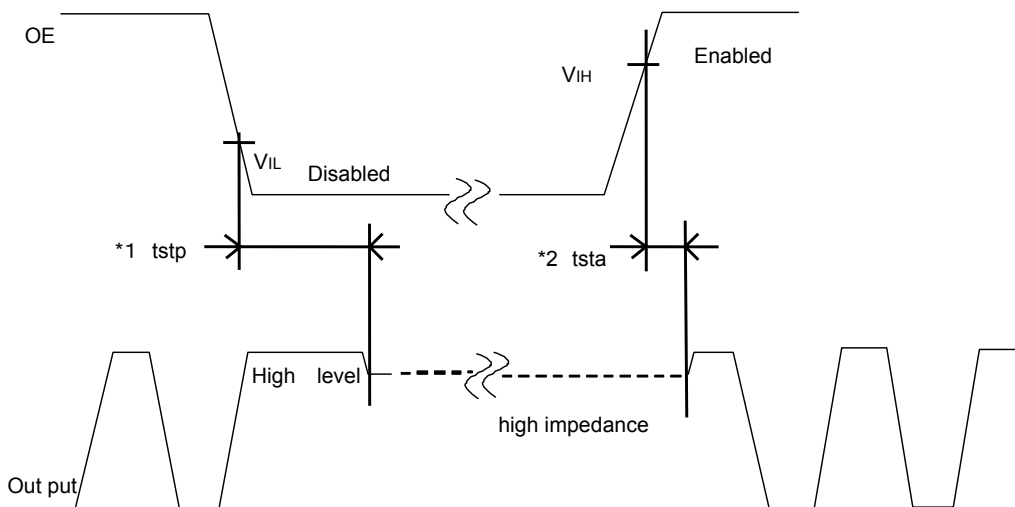

*1 The time taken from OE = V_{IL} to output = Disable (high impedance)

*2 The time taken from OE = V_{IH} to output = Start

Output start : V_{OH} ≥ 80% V_{CC}, V_{OL} ≤ 20% V_{CC}, f_{out} = f_o ± 1 000 × 10⁻⁶

4) OE Control timing

OE function is used on the voltage below supply voltage.

OE control timing differs from Vcc control timing

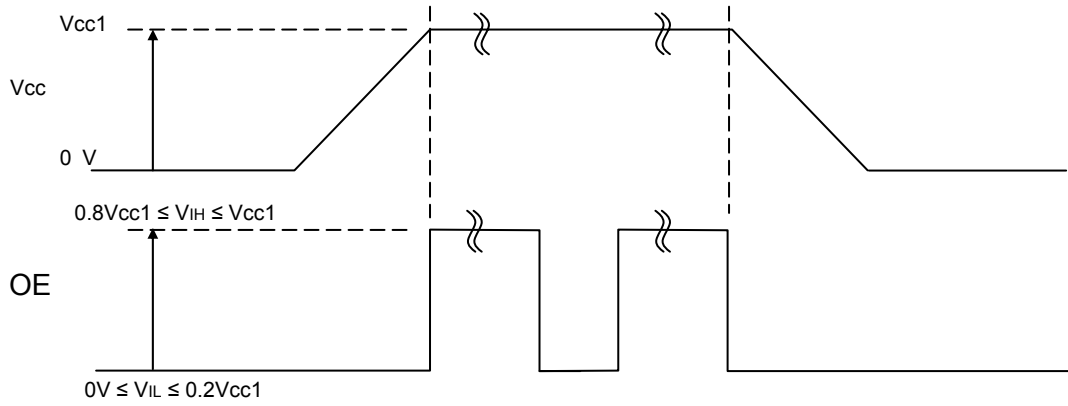

OE terminal is connected to Vcc terminal

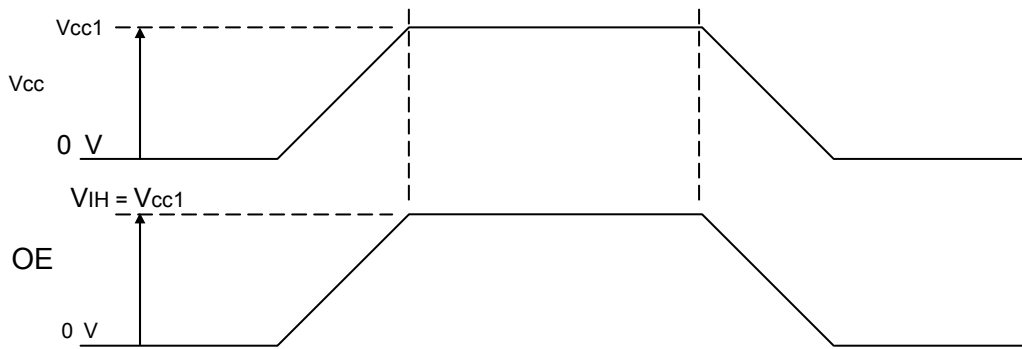

4) Timing of an output frequency signal

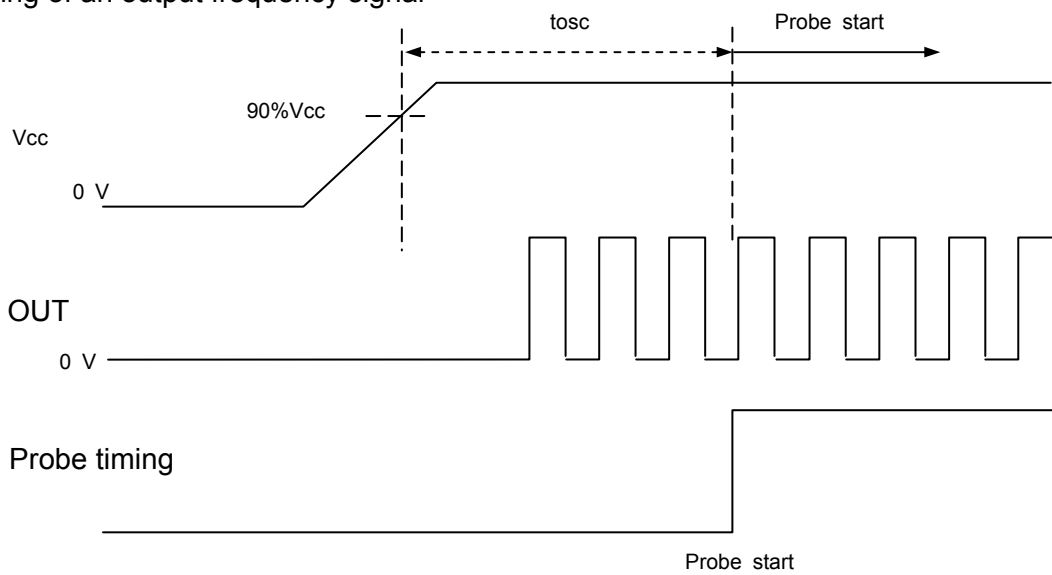

[8] Environmental and mechanical characteristics

(The company evaluation condition We evaluate it by the following examination item and examination condition.)

No.	Item	Value *1		Test Conditions
		$\Delta f / f *2$ [1×10^{-6}]	Electrical characteristics	
1	High temperature storage	*3 ± 20	Satisfy Item [5] after test.	+125 °C \times 1 000 h
2	Low temperature storage	*3 ± 10		-40 °C \times 1 000 h
3	High temperature bias	*3 ± 15		+85 °C \times V _{CC} Max. \times 1 000 h
4	Low temperature bias	*3 ± 10		-40 °C \times V _{CC} Max. \times 1 000 h
5	Temperature humidity bias	*3 ± 15		+85 °C \times 85 %RH \times V _{CC} Max. \times 1 000 h
6	Temperature cycle	*3 ± 10		-40 °C \leftrightarrow +125 °C 30 min. at each temperature 100 cycles
7	Resistance to soldering heat	± 3		Convection reflow soldering furnace (3 times) Ref. IPC/JEDEC J-STD-020D.1
8	Shock	± 3		Free drop from 750 mm height on a hard wooden board for 3 times
9	Vibration	± 2		10 Hz to 55 Hz amplitude 0.75 mm 55 Hz to 500 Hz acceleration 98 m/s ² 10 Hz \rightarrow 500 Hz \rightarrow 10 Hz 15 min./cycle 6 h (2 hours , 3 directions)
10	Seal	1×10^{-9} Pa·m ³ /s		He leakage detector
11	Solderability	Termination must be 95 % covered with fresh solder		Dip termination into solder bath at +235 °C \pm 5 °C for 5 s. (Using Rosin Flux)
12	Pull - off	No peeling-off at a solder part		10 N press for 10 s \pm 1 s Ref. EIAJ ED-4702

< Notes >

*1 Each test done independently.

*2 Measuring 2 h to 24 h later leaving in room temperature after each test.

*3 Initial value shall be measured after 24 h storage at room temperature after pre-conditioning.
Pre-conditioning: Reflow (3 times)

Convection reflow condition (IPC/JEDEC J-STD-020D.1)

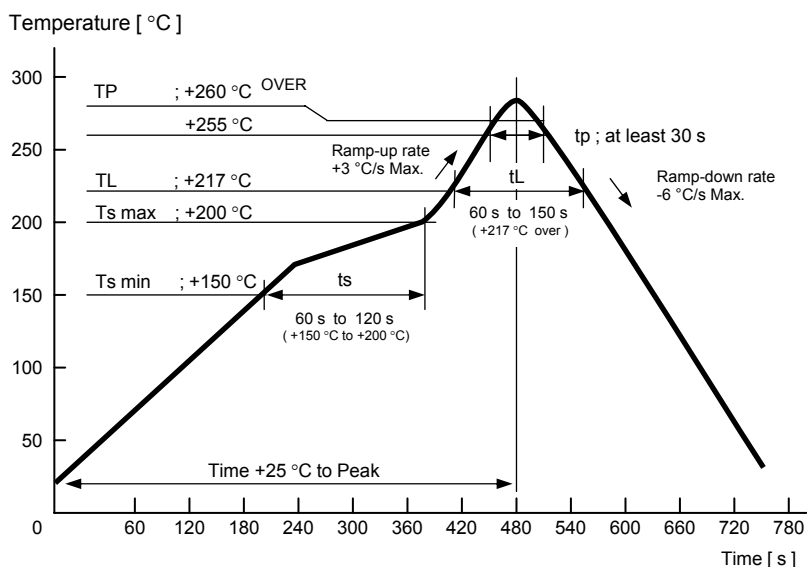

[9] Electro Static Discharge

· ESD

Item	Electrostatic discharge	Test term
HBM	1200 V Min.	EIAJ ED-4701-1 C111A,100 pF,1.5 k Ω , 3 times
MM	200 V Min.	EIAJ ED-4701-1 C111,200 pF, 0 Ω , 1 time

[10] Dimensions and marking layout

1) Dimensions

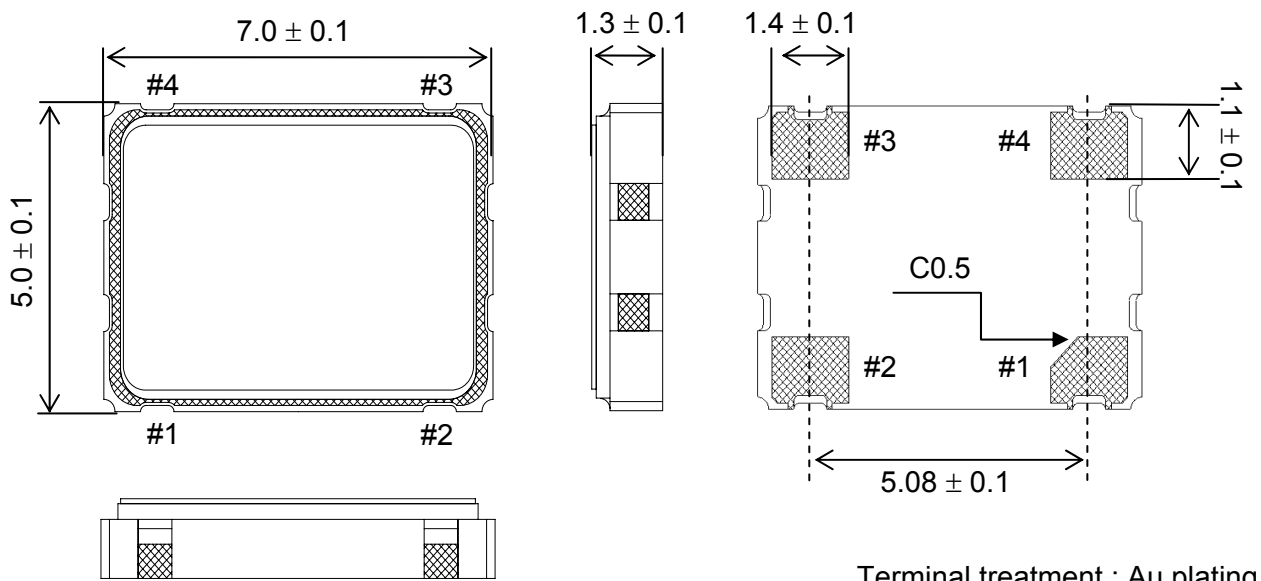

Terminal treatment : Au plating
Unit : mm

2) Marking layout

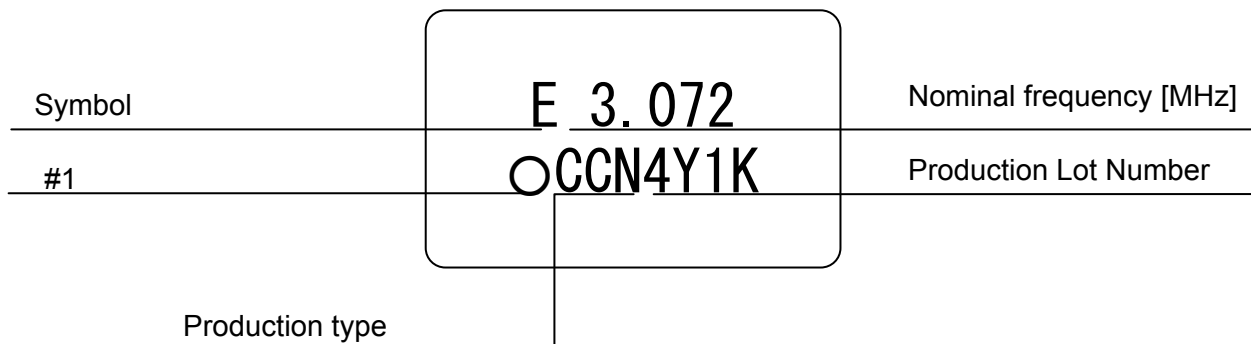

- ◆ The above marking layout shows only marking contents and their approximate position and it is not for font, size and exact position.
- ◆ Output frequency shall indicate 5 digits (include decimal point), if the value of frequency over 5 digits, the least significant digits will be omitted.

[11] Notes

- 1) This device is made with C-MOS IC. Please take necessary precautions to prevent damage due to electrical static discharge.
- 2) We recommends a 0.01 μF to 0.1 μF capacitor must be connected near V_{CC} between V_{CC} and GND to obtain stable operation and protect against power line ripple.
- 3) V_{CC} and GND pattern shall be as large as possible so that high frequency impedance shall be small.
- 4) We cannot recommend to put filtering element into power line so as to reduce noise. Oscillator might be unstable oscillation because high frequency impedance of power line become higher. When use filtering element, please verify electrical construction and or element's spec.
- 5) We doesn't recommend to power on from intermediate electric voltage or extreme fast power on, Those powering conditions may cause no oscillation or abnormal oscillation.
- 6) Power ripple: 200 mV P-P max. Start up time (0 % V_{CC} →90 % V_{CC}) of power source should be more than 150 μs .
- 7) A long output line may cause irregular output, so try to make the output line as short as possible.
- 8) Other high-level signal lines may cause incorrect operation, so please do not place high level signal line close to this device.
- 9) This device contains a crystal resonator, so please don't expose excessive shock or vibration. We recommends store device under normal temperature and humidity to keep the specification.
- 10) An automatic insertion is available, however, the internal crystal resonator might be damaged in case that too much shock or vibration is applied by machine condition. Be sure to check your machine condition in advance.
- 11) Ultrasonic cleaning can be used on the SG7050CCN, however, since the oscillator might be damaged under some conditions, please exercise in advance.
- 12) We recommends to use and store under room temperature and normal humidity to secure frequency accuracy and prevent moisture.
- 13) OE-pin has pull-up resistor internally. The resistor value is switched depending on input voltage. Please refer to electrical characteristics.
- 14) Lid is electrically connected to GND. Please don't apply electrical voltage.

[12] Recommendable patterning

The soldering pad sample indicated as like following:

Soldering position (Unit : mm)

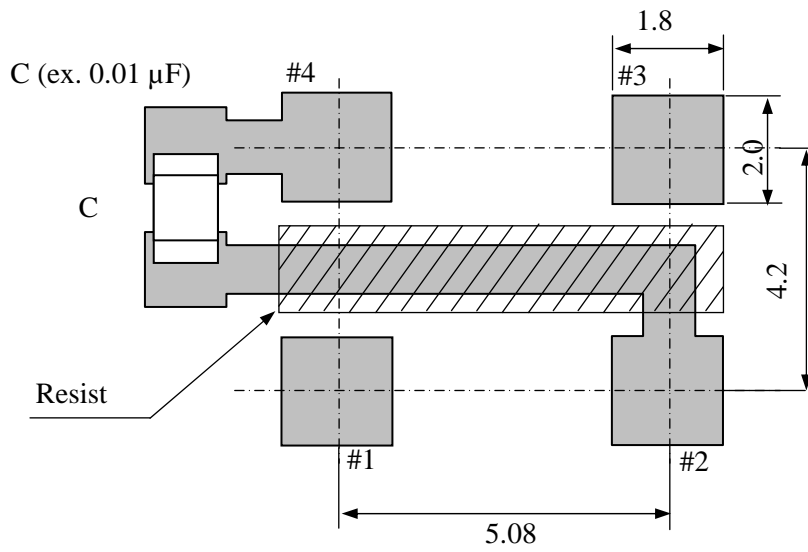

To maintain stable operation, provide a 0.01 μ F to 0.1 μ F by-pass capacitor at a location as near as possible to the power source terminal of the crystal product (between Vcc - GND).

TAPING SPECIFICATION

I . Application

This standard will apply to 7×5 Ceramic package.

Spec : CA package

II . Contents

Item No.	Item	Page
[1]	Taping specification	1 to 2
[2]	Inner sleeve	3
[3]	Shipping carton	
[4]	Marking	4
[5]	Quantity	
[6]	Storage environment	
[7]	Handling	

[1] Taping specification

Subject to 「EIA-481」 and 「IEC-60286」

(1) Tape dimensions TE-1612L

Material of the carrier tape : PS

Material of the top tape : PET

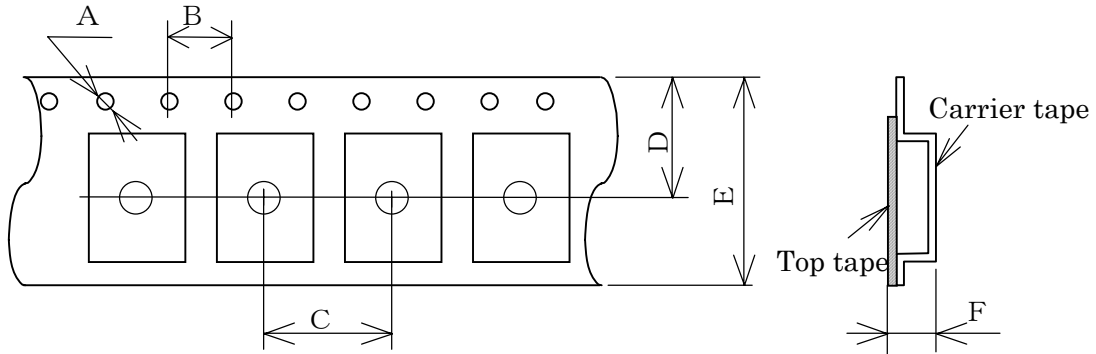

Symbol	A	B	C	D	E	F
Value	$\phi 1.5$	4.0	8.0	9.25	16.0	2.3

Unit : mm

(2) Reel dimensions

Material of the reel : Conductive polystyrene

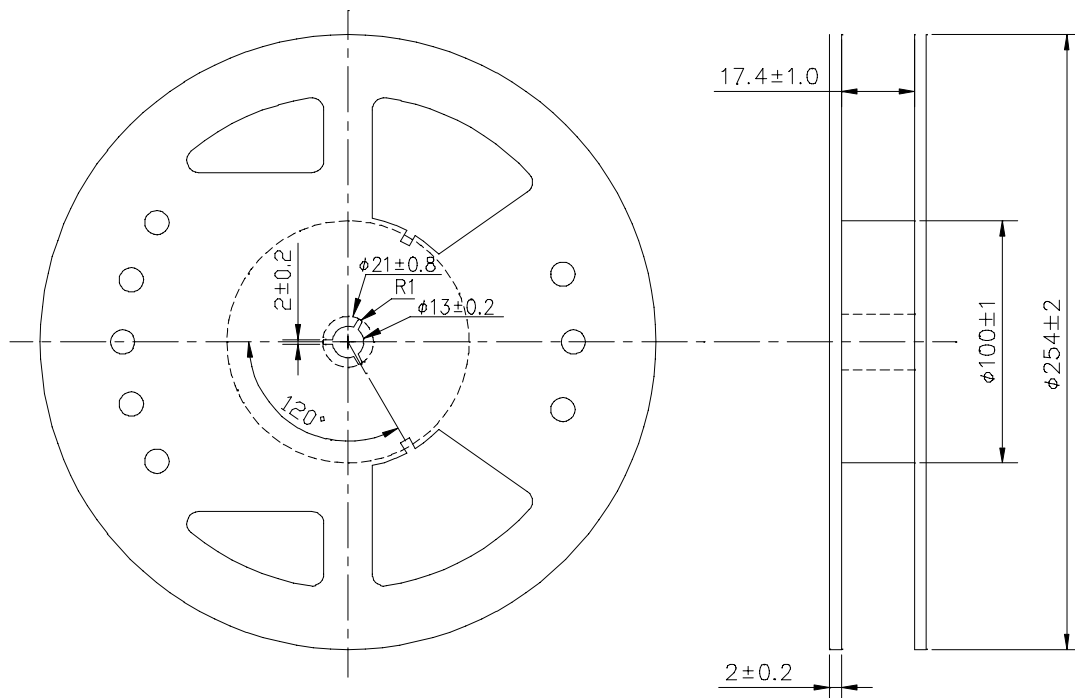

(3) Packing

① Tape & reel

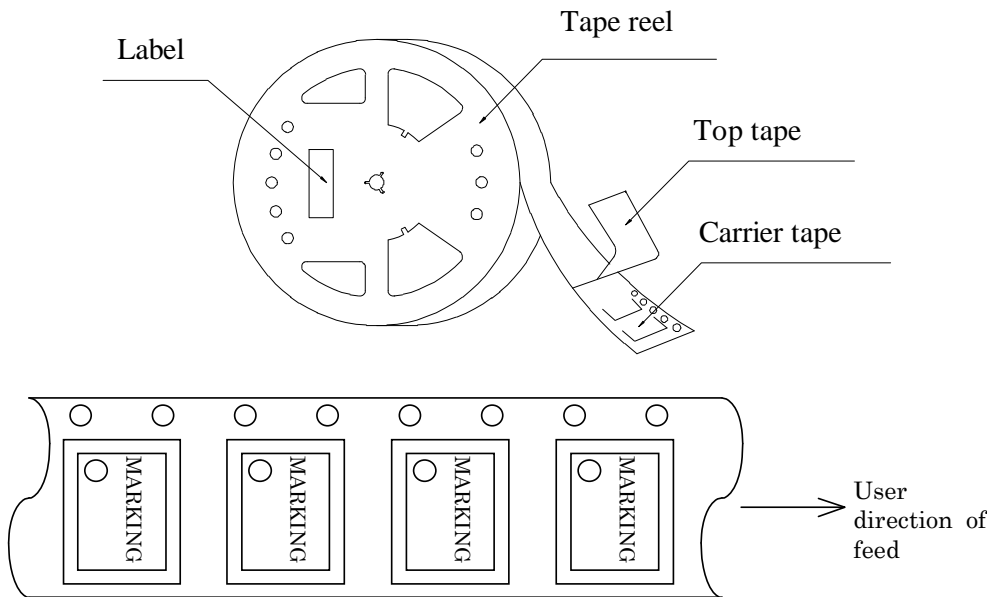

② Start & end point

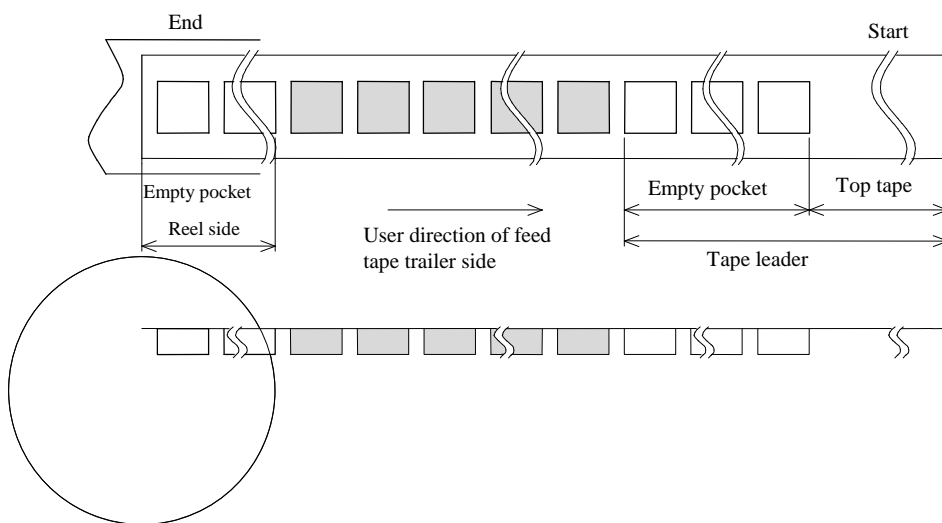

Item		Empty space
Tape leader	Top tape	Min. 1 000 mm
	Carrier tape	Min. 160 mm
Tape trailer	Top tape	Min. 0 mm
	Carrier tape	Min. 160 mm

(4) Peel force of the cover tape

- ① angle : cover tape during peel off and the direction of unreeling shall be 165° to 180°.
- ② peel speed : 300 mm / min.

[2] Inner sleeve

a) Packing to antistatic bag

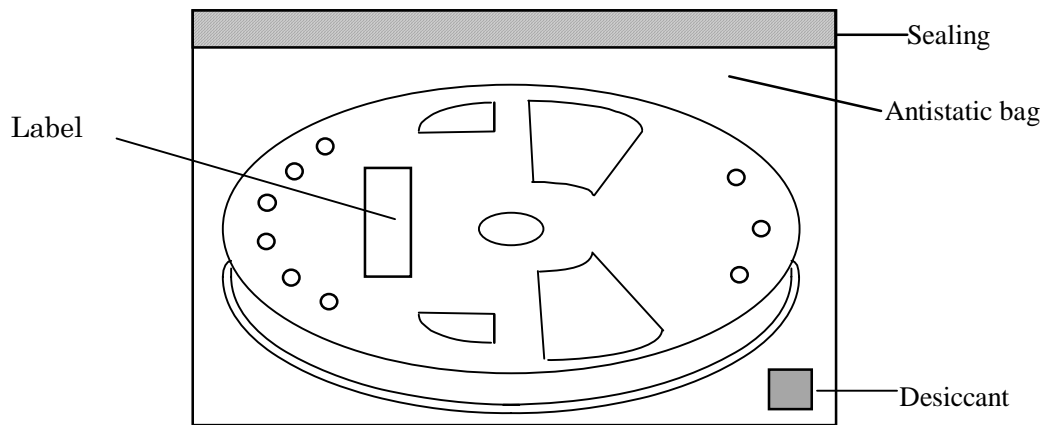

b) Packing to inner sleeve

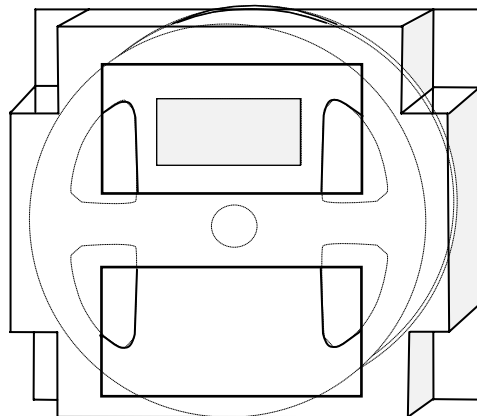

* There is also a case to put the two reel.

[3] Shipping carton

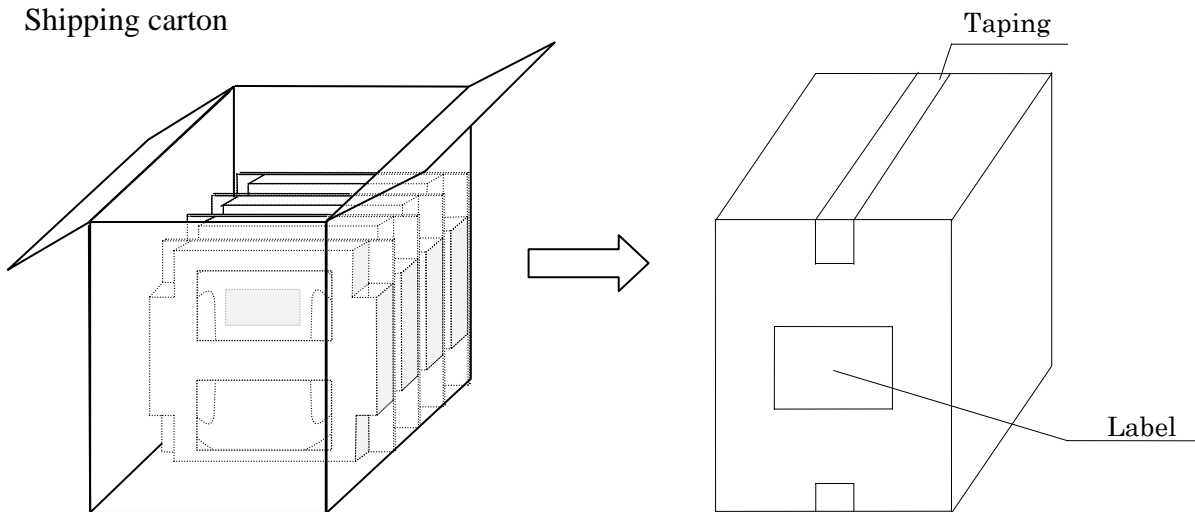

[4] Marking

(1) Reel marking

- Reel marking shall consist of :
 - 1) Parts name
 - 2) Quantity
 - 3) Manufacturing date or symbol
 - 4) Manufacturer's date or symbol
 - 5) Others (if necessary)

(2) Shipping carton marking

- Shipping carton marking shall consist of :
 - 1) Parts name
 - 2) Quantity

[5] Quantity

- 1 000 pcs./reel

[6] Storage environment

- (1) Before open the packing, we recommend to keep less than +30 °C and 85 %RH of Humidity, and to use it less than 6 months after delivery.
- (2) We recommend to open Package in immediately before use. After open Package, We recommend to keeps less than 6 month. No need dry air before soldering work if it is less than temperature +30 °C, 85 humidity %RH.
- (3) Not to expose the sun.
- (4) Not to storage with some erosive chemicals.
- (5) Nothing is allowed to put on the reel or carton to prevent mechanical damage.

[7] Handling

- To handle with care to prevent the damage of tape, reel and products.

- PROCESS QUALITY CONTROL Preliminary -

No. SG7050CxN - 00 - ASE - 1

CRYSTAL OSCILLATOR : SG7050CxN

Sep.10.2013

Manufacturing process chart		No.	Section In Charge	Standards	Inspection, Control Item	Instruments	Inspection Methods	Record
<p>The diagram shows a manufacturing process flow. It starts with 'In-coming Inspection' (diamond 1) for Lid, Crystal, IC, and Base. The process steps are: 2 Chip Setting, 3 Package Set, 4 Die Attach, 5 Wire Bonding, 6 Crystal-Mounting, 7 Frequency Adjusting (Crystal), 8 Hermetic Sealing, 9 High Temp Treatment, 10 Leakage, 11 LDL Inspection, 12 Marking, 13 Electrical Characteristic Inspection, 14 Temp Characteristic, 15 Appearance Inspection, 16 Outgoing Inspection, 17 Taping, and 18 Packing. Inspection points are marked with diamonds and process steps with circles.</p>	1	Inspection Section	Purchasing Specification Incoming Inspection Standard	Appearance Dimension	Microscope	Sampling	Data sheet	
	2	China Plant (Production Section)	Manufacturing Instruction Sheet	Appearance	Microscope	100% Inspection	Data sheet	
	3	China Plant (Production Section)	Manufacturing Instruction Sheet	Appearance	Microscope	Sampling	Data sheet	
	4	China Plant (Production Section)	Manufacturing Instruction Sheet	Appearance Frequency	Microscope	Sampling	Data sheet	
	5	China Plant (Production Section)	Manufacturing Instruction Sheet	Bonding strength Appearance	Pull tester / Gauge Microscope	Sampling	Data sheet	
	6	China Plant (Production Section)	Manufacturing Instruction Sheet	Mounting strength Appearance	Pull tester Microscope	Sampling 100% Inspection	Data sheet	
	7	China Plant (Production Section)	Manufacturing Instruction Sheet	Appearance Frequency	Microscope Counter	Sampling 100% Inspection	Data sheet	
	8	China Plant (Production Section)	Manufacturing Instruction Sheet	Appearance	Microscope	Sampling	Data sheet	
	9	China Plant (Production Section)	Manufacturing Instruction Sheet	—	—	—	—	
	10	China Plant (Production Section)	Manufacturing Instruction Sheet	Leakage inspection	Measuring equipment	100% Inspection	Data sheet	
	11	China Plant (Production Section)	Manufacturing Instruction Sheet	Characteristic inspection	Measuring equipment	100% Inspection	Data sheet	
	12	China Plant (Production Section)	Manufacturing Instruction Sheet	Appearance	Visual Inspection	Sampling	Data sheet	
	13	China Plant (Production Section)	Manufacturing Instruction Sheet	Electrical characteristic Master Check	Measuring equipment	100% Inspection	Data sheet	
	14	China Plant (Production Section)	Manufacturing Instruction Sheet	Electrical characteristic Master Check	Measuring equipment	Sampling	Data sheet	
	15	China Plant (Production Section)	Manufacturing Instruction Sheet	Appearance Master Check	Microscope	100% Inspection	Data sheet	
	16	China Plant (Production Section)	Delivery Specifications Outgoing Inspection Standard	Electrical characteristic Appearance	Measuring equipment Microscope	Sampling	Data sheet	
	17	China Plant (Production Section)	Manufacturing Instruction Sheet	Tape peeling strength Frequency check function	Peeling strength test machine	Sampling	Data sheet	
	18	China Plant (Production Section)	Manufacturing Instruction Sheet Daily Shipping List	Customers Type Quantity	—	—	Delivery Slip	

Structure diagram SG7050CCN

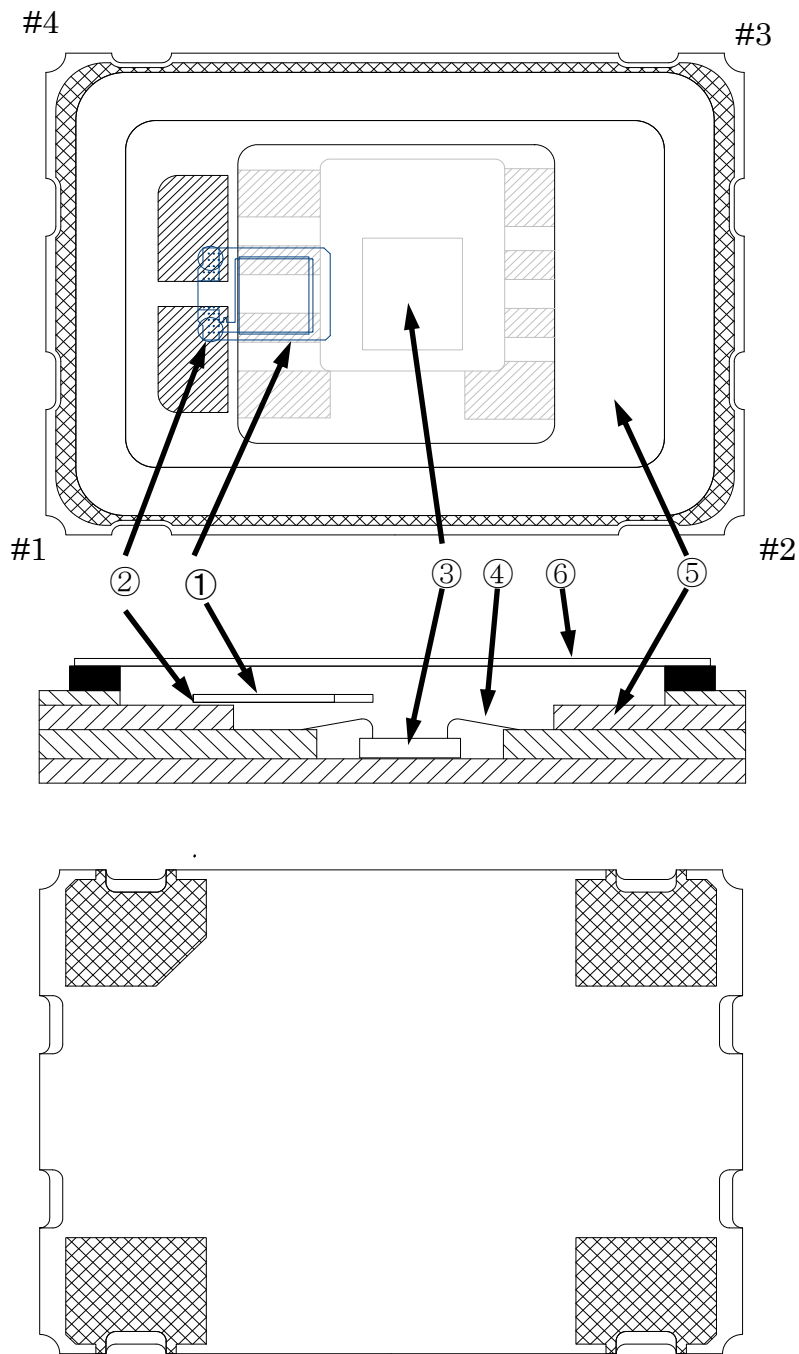

L I S T

Name of part		Material
①	Crystal chip	AT cut
②	Crystal adhesive	Ag paste
③	IC	C-MOS
	IC conductive adhesive	Ag paste
④	Bonding wire	Au
⑤	Package	Ceramic (Al ₂ O ₃)
⑥	LID	Cover