Product Specification

(KYOCERA CORPORATION CERAMIC RESONATOR SPECIFICATION)

RoHS compliant

CONFIRMED

(Please sign here and send one copy back to us.)

Specification No.	<i>EQM08-5KC-G5PQ803-00</i> (QK-SB210-PE0623-A)		
Type Name	<i>PRQV12.00CR1510Y00L</i>		
00	Apr, 16, 2014		
Approved by	<i>T.Sugihara</i>		
Checked by	<i>K.Katsuyama</i>		
Checked by	<i>T.Matsuoka</i>		
Issued by	<i>N.Arima</i>		

1. Scope

This document shall cover the specifications of the ceramic resonator applied for clock oscillator of a microcomputer.

2. Kyocera's Type Name

PRQV12.00CR1510Y00L

3. Customer's Type Name

-

4. Electrical Characteristics

Table 1 Product Specification

Items	Specifications
Oscillating Frequency	12.00 MHz
Initial Frequency Tolerance	± 0.15 %
Resonant Impedance	200 Ω max.
Temperature Characteristics on Oscillating Frequency (Temperature Drift)	± 0.10 % (-40 to +125 °C)
Standard Test IC	MC74HCU04 (Freescale)
Withstanding Voltage	100V D.C. 10 seconds max
Max. Input Signal Voltage	15 Vp-p
Insulation Resistance	100 MΩ min (at 10V D.C.)
Operating Temperature Range	-40 to +125 °C
Storage Temperature Range	-40 to +125 °C
Aging for 10 Years on Oscillating Frequency	±0.05 % at 25°C from initial value

4-1. Measurement Condition

The reference temperature shall be 25 ± 2 °C. The measurement shall be performed in the temperature range from 15 °C to 35 °C unless otherwise the result is doubtful.

4-2. Measurement Circuit

Oscillating frequency shall be measured using the Kyocera standard test circuit shown in Fig 1.



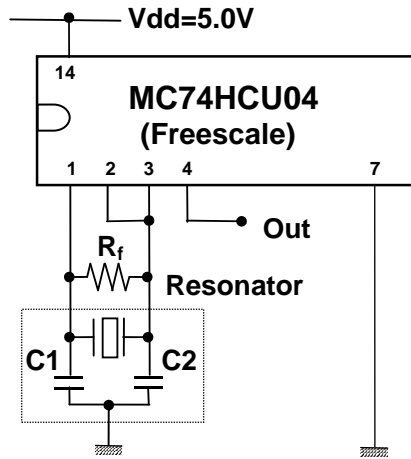

$R_f=1M\Omega$
 $C1=C2= 10\text{ pF}$ (Reference)

Fig 1 Standard Measuring Circuit

5. Appearance & Dimensions

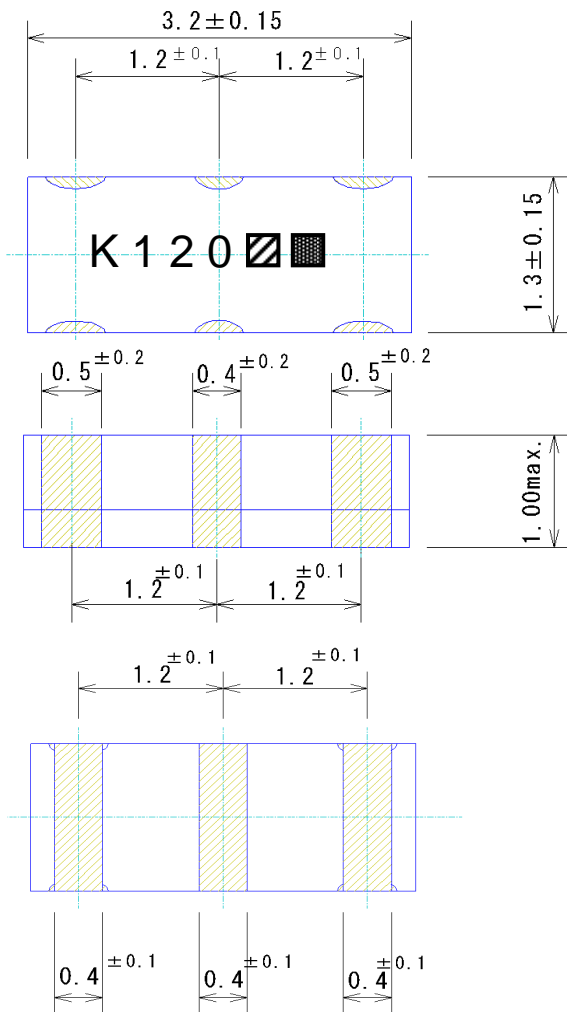

Oscillating Frequency

e.g:120 show the oscillating frequency of 12.00 MHz.

Date Code

2013	Jan. ~ Dec.	A~M (except "I")
2014	Jan. ~ Dec.	N~Z (except "O")
2015	Jan. ~ Dec.	a~m (except "i")
2016	Jan. ~ Dec.	n~z (except "o")

Note: The alphabet should be repeated after Jan.2017.

Day Code

Day	1	2	3	4	5	6	7	8	9	10	
Code	A	B	C	D	E	F	G	H	J	K	
Day	11	12	13	14	15	16	17	18	19	20	
Code	L	M	N	P	Q	R	S	T	U	V	
Day	21	22	23	24	25	26	27	28	29	30	31
Code	W	X	Y	Z	a	b	c	d	e	f	g

Appearance

There should be no mechanical damages, which are markedly out of this specification.

Terminal: Ni/Sn plating

Fig 2 Dimensions

Unit: mm



6. Part Numbering Guide

PRQV 12.00 C R 15 10 Y 00L
A B C D E F G H

- A. Series (MHz Band SMD Ceramic Resonator)
- B. Oscillating Frequency (eg. 12.00 MHz)
- C. Type
- D. Packing (Tape & Reel 3000 pcs/Reel)
- E. Initial Frequency Tolerance
- F. Built-in Capacitor(10pF: Standard)
- G. Operating Temp. Range
- H. Unique Code

7. Environmental Characteristics

Table 2 Environmental Characteristics

Items	Conditions
7-1. Humidity	After leaving in a chamber at 80 to 85 % R.H. and $85 \pm 2^\circ\text{C}$ for 1000 +12/-0 hours and then left at room temperature for 1 hour the resonator shall meet the specifications shown in Table 3.
7-2. High Temperature	After leaving in a chamber at $125 \pm 2^\circ\text{C}$ for 1000 +12/-0 hours and then left at room temperature for 1 hour, the resonator shall meet the specifications shown in Table 3.
7-3. Low Temperature	After leaving in a chamber at $-40 \pm 3^\circ\text{C}$ for 1000 +12/-0 hours and then left at room temperature for 1 hour, the resonator shall meet the specifications shown in Table 3.
7-4. Temperature Cycle	After leaving in a chamber at $-40 \pm 3^\circ\text{C}$ for 30 minutes, then the resonator is left at $125 \pm 2^\circ\text{C}$ for 30 minutes. This procedure is one cycle. After leaving in 1000 cycles, and then left at room temperature for 1 hour, the resonator shall meet the specifications shown in Table 3.
7-5. Mechanical Shock	After applying the acceleration at 29430m/sec^2 {3000G} in each of X, Y and Z axis (each 3 time), the resonator shall meet the specifications in Table 3.
7-6. Vibration	After applying the vibration at amplitude 1.5 mm and 10 to 55 Hz of vibration frequency in each of 3 mutually perpendicular directions for 1 hour, the resonator shall meet the specifications shown in Table 3.
7-7. Solderability	At first, being soaked in the Methanol (JIS K1501) solution containing Rosin (JIS K5902) for 5 seconds and next being soaked in a bath of Pb/Sn solder at $235 \pm 5^\circ\text{C}$ for 4 ± 0.5 seconds, then more than 95% the surface of the electrode terminal shall be soldered.
7-8. Reflow Soldering	At first, leaving at 150 to 180°C of pre-heat for 90 to 120 seconds, next left at peak temperature $260+0/-5^\circ\text{C}$, over 230°C for 30 to 40seconds (2times). Finally leaving at room temperature for 1 hour. The resonator shall meet the specifications shown in Table 3.
7-9. Cleaning	1)Ultrasonic cleaning: The resonator is washed with iso-propyl alcohol at room temperature with condition of 20KW/m ³ and 28kHz for 60sec. No significant damage on the resonator shall occur and marking shall be safely readable. 2)Soaking cleaning: The resonator is soaked in iso-propyl alcohol at room temperature for 90sec. No significant damage on the resonator shall occur and marking shall be safely readable.
7-10. Bend strength	<p>After soldered on the board specified as below, then the load which cause 3 mm bent to the board is applied, the resonator shall meet the specifications in Table 3 and cause no defect in the appearance.</p>  <p>Material: Glass-epoxy Thickness: 0.8mm / Size: L100mm x W40</p> <p>Recommendable land pattern Solder paste: 0.2mm Thickness</p> <p>Fig.3 Bend Strength</p>

Table 3 Environmental Characteristics Standard

Items	Specifications
Oscillating Frequency (from initial value)	±0.2 % max
Resonant Impedance	250 Ω max.

8. Recommendable land pattern

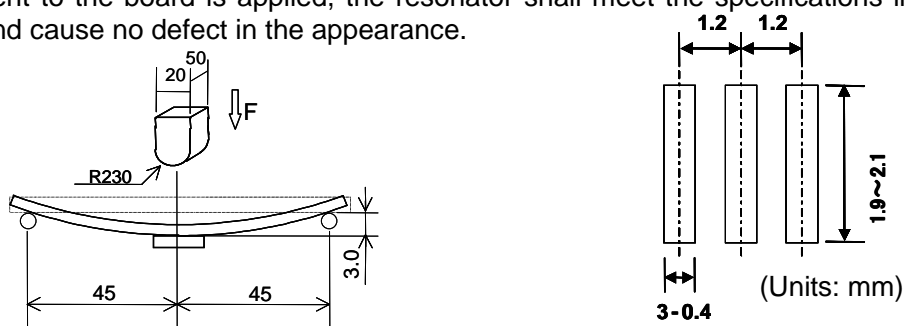
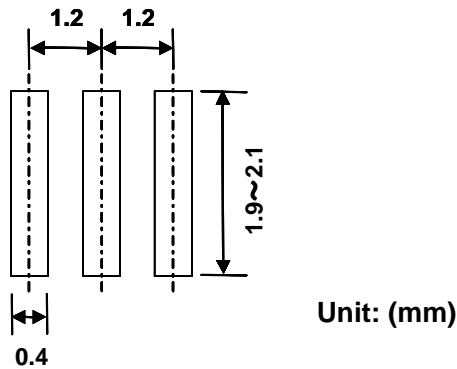

Fig.4 Recommended Land pattern

9. Recommendable reflow profile

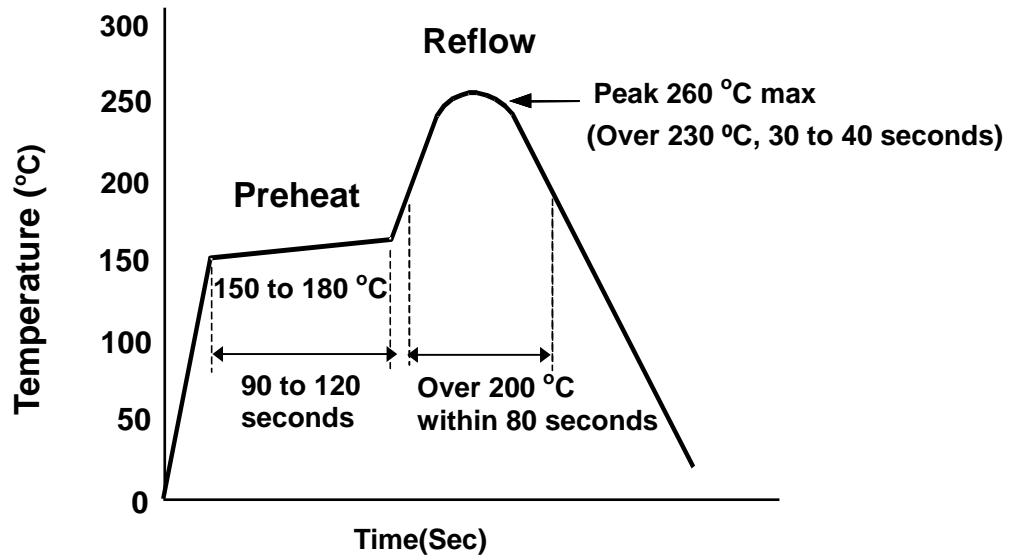

Fig.5 Recommended IR Reflow profile

10. Taping Specifications

10-1. Tape

10-1-1. Dimensions

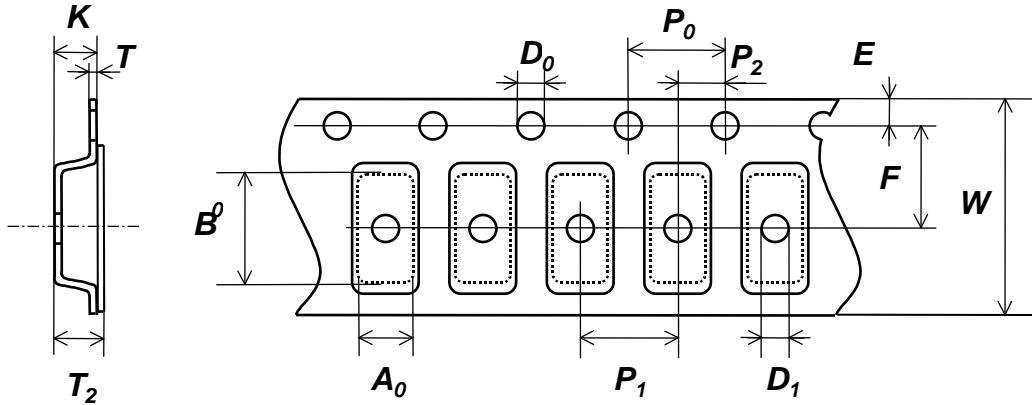

Fig.6 Emboss Carrier Tape Dimensions

Table 4 Emboss Carrier Tape Dimensions

Unit: (mm)

Symbol	A_0	B_0	W	F	E	P_1	P_2
Dimensions	1.55 ± 0.2	3.45 ± 0.2	8.00 ± 0.3	3.50 ± 0.05	1.75 ± 0.1	4.00 ± 0.1	2.00 ± 0.05
Symbol	P_0	D_0	T	T_2	K	D_1	
Dimensions	4.00 ± 0.1	$1.50 + 0.1 / - 0$	0.25 ± 0.05	1.40max.	1.10 ± 0.2	$1.0 + 0.1 / - 0$	

10-2. Taping

10-2-1. Taping Quantity

One reel of the tape shall pack 3000 pcs resonators maximum. No resonator shall be missing and contained continuously in pocket.

10-2-2. Reel Dimensions

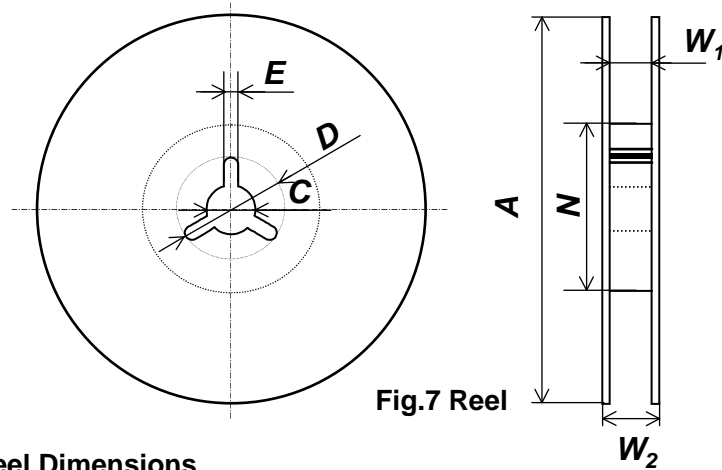

Fig.7 Reel

Table 5 Reel Dimensions

Unit: (mm)

Symbol	A	N	W_1	W_2
Dimensions	$180 + 0 / - 9$	50 min	9.0 ± 0.3	12.4 Max
Symbol	C	D	E	
Dimensions	13.0 ± 0.5	21.0 ± 0.8	2.0 ± 0.5	

10-2-3. Taping Package

Taping package shall be composed of leader, blank pockets and loaded pockets, as described in Fig.8. The peeling force between top and carrier tapes shall be in the range from 0.1N {10gf} to 0.7N {70gf} with the condition described in Fig.9.

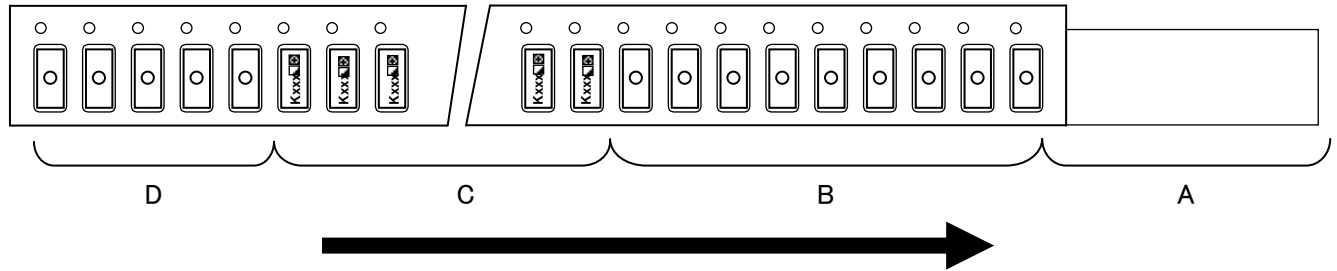

- A: Leader Tape
- B: Blank Pocket (160 mm min)
A+B: 400- 560 mm
- C: Loaded Pocket
- D: Blank Pocket (40 – 190 mm)

Fig.8 Packing Method

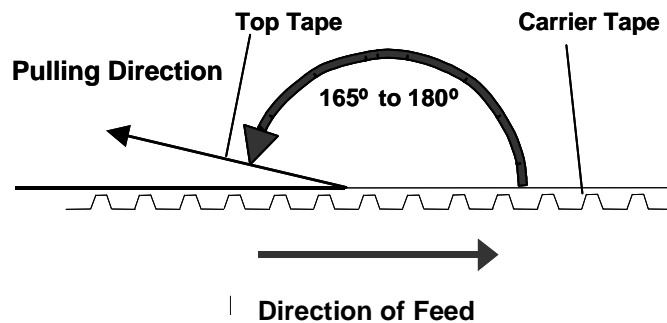

Fig.9 Peeling Strength

10-2-5. Reel Label

A reel label shall consist as below.

- A) Customer P/N
- B) Lot No.
- C) Quantity
- D) Shipping date
- E) Vender name

10-2-6. Exterior Package Label

The resonators shall be packed properly to avoid defect in transportation and the marking of the exterior package shall contain information described as below.

- A) Name of customer
- B) P/O No.
- C) Customer P/N
- D) Lot No.
- E) Quantity
- F) Shipping date
- G) Vender name

11. Agreement on this Specification

Should any part of the content of this specification become questionable, it shall be settled by mutual deliberations.

12. Remarks on Usage

12-1. In case that such stronger shock and vibration, higher temperature that shall be specified were to be applied to the resonator, it would occasionally become out of order. So please pay plenty of attention to its usage.

12-2. This part is available for reflow soldering only. The ceramic resonator may be damaged in case of reflow soldering at temperatures higher than 260 °C.

12-3. Ensure that your circuit design is fully characterized for your IC. For recommendations of component values, please contact IC manufacturer or our local sales office before mass production. Please note there may be some oscillation problems in case of not suitable circuit design.

12-4. Storage condition

Please use the ceramic resonator within one year from the shipping date under room storage condition less than 30 °C and 60%RH with the shipped package.

12-5. Fail-safe

Be sure to provide an appropriate fail-safe function on your system or subsystem to prevent a second damage that may be caused by an abnormality or failure related to our product.

12-6. Limitation of use

Make sure to contact us in advance before considering using this product for the following applications which would require particularly high reliability due to possibility of direct harm to lives and/or properties.

- (1) Use in aerospace or space
- (2) Use in seabed or underground
- (3) Use in control of power station – firepower, waterpower, nuclearpower, etc
- (4) Use in medical treatments including instruments related to lifesaver
- (5) Use in transportation – trains, ships, etc.
- (6) Use in traffic controls
- (7) Use in protection/prevention against disasters or crimes
- (8) Others – Use in the equivalent applications mentioned above

12-7. This product is designed and manufactured with intention to be used in general electronic equipments for standard applications but with no intention to be used in the following environments which may affect performance of this product. Therefore, make sure to have enough confirmation on performance and reliability of this product in the following environments in advance before use.

- (1) Use in liquids such as water, oil, medical liquid, organic solvent, etc
- (2) Use in direct sunshine, rain, wind, or dust/dirt
- (3) Use in sea wind or place with corrosive gas such as Cl₂, H₂S, NH₃, SO₂, NO₂, etc
- (4) Use in environment with strong static electricity or electromagnetic wave
- (5) Use in located nearby to heat generating part or flammable materials such as vinyl wires
- (6) Use in sealed or coated by materials such as resin, etc
- (7) Use in condensation

13. Placement of the Resonator

The resonator should be placed on PCB as described follow to avoid any mechanical stresses applied to the part.

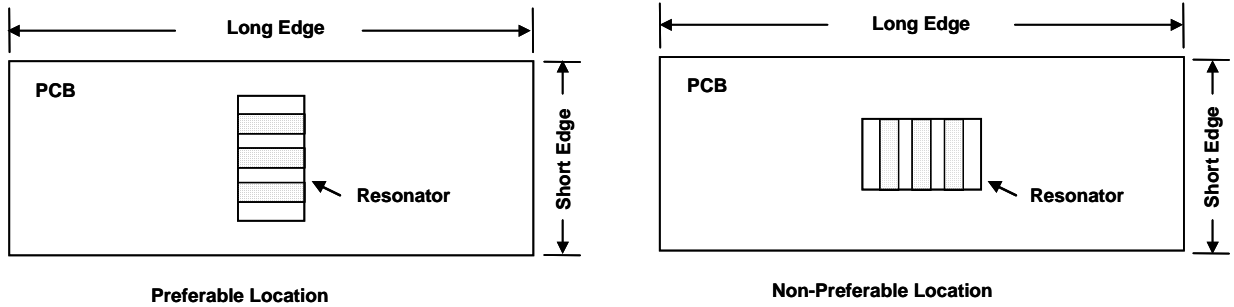

Fig.10 Mounting Direction

14. Environment Hazardous Substance (RoHS Compliant Certificate)

The environment hazardous substance in Table 6 is not being used to the raw materials and also manufacturing process of this product and packaging (except impurities).

Lead (Pb) used in the resonator products is exempted from RoHS requirements in the ANNEX.

Table 6 Enviromental Load Substance

Substances		Content	
Substances Inhibited by the Law in Japan		Products	Reel and Packages
1	Cadmium and cadmium compounds	None	None
2	PBB (polybrominated biphenyl) s and PBDE (polybrominated biphenyl ether) s	None	None
3	Chlorinated paraffins (Chlorines Flame retarder/Plasticizer)	None	None
4	PCB (polychlorinated biphenyl) s	None	None
5	Poly chloridation naphthalenes	None	None
6	Organo tin compounds (Tributyl tins/ Triphenyl tins)	None	None
7	Asbestos	None	None
8	Azo compounds	None	None
Others			
9	Lead (Pb)	Yes	None