

RECIPIENT

## SPECIFICATIONS

**Product No. : X1E000381A10000**

**MODEL : FA2016AA**

**SPEC. No. : A17-415-1B**

**DATE : Oct. 26. 2017**

### SEIKO EPSON CORPORATION

8548 Naka-minowa  
Minowa-machi Kamiina-gun  
Nagano-ken  
399-4696 Japan

CHECKED K. Yamanaka / TD Engineering Department Manager  
Kunihito Yamanaka

CHECKED M. Shirotori / TD Production Engineering Department Senior Staff  
Masashi Shirotori

CHECKED Y. Kurahashi / TD • CS Quality Assurance Department Manager  
Yoshitaka Kurahashi

PREPARED Emi Oguchi / TD • CS Quality Assurance Department Senior Staff  
Emi Oguchi

# SPECIFICATIONS

## 1. Application

- 1) This document is applicable to the crystal unit FA2016AA that are delivered.  
to from Seiko Epson Corp.
- 2) This product is compliant with RoHS Directive.
- 3) This Product supplied (and any technical information furnished, if any) by Seiko Epson Corporation shall not be used for the development and manufacture of weapon of mass destruction or for other military purposes.  
Making available such products and technology to any third party who may use such products or technologies for the said purposes are also prohibited.
- 4) This product listed here is designed as components or parts for electronics equipment in general consumer use.  
We do not expect that any of these products would be incorporated or otherwise used as a component or part for the equipment, which requires an extra high reliability, such as satellite, rocket and other space systems, and medical equipment, the functional purpose of which is to keep life.
- 5) This FA2016AA is authorized for Infotainment System for automobile only.
- 6) This product conforms to automotive part standard " AEC-Q200 ".

## 2. Product No. / Model

X1E000381A10000 / FA2016AA

## 3. Packing

It is subject to the packing standard of Seiko Epson Corp.

## 4. Warranty

Defective parts which originate with us are replaced free of charge in the case of defects being found with 12 months after delivery.

## 5. Amendment and/or termination

Amendment and/or termination of this specification is subject to the agreement between the two parties.

## 6. Contents

Item No.	Item	Page
[1]	Absolute maximum ratings	2
[2]	Operating range	2
[3]	Electrical characteristics	2
[4]	Environmental and mechanical characteristics	3
[5]	Dimensions and circuit	4
[6]	Recommended soldering pattern and marking layout	5
[7]	Notes	6

### [ 1 ] Absolute maximum ratings

No.	Parameter	Symbol	Rating value			Unit	Note
			Min	Typ.	Max.		
1	Storage temperature	T <sub>stg</sub>	-40	-	+125	°C	Depends on the Environmental Characteristics specifications.

### [ 2 ] Operating range

No.	Parameter	Symbol	Value			Unit	Note
			Min	Typ.	Max.		
1	Operating temperature	T <sub>use</sub>	-40	-	+85	°C	
2	Drive level	DL	1	100	200	uW	

### [ 3 ] Electrical characteristics

No.	Parameter	Symbol	Standard	Unit	Conditions
1	Nominal frequency	f <sub>nom</sub>	24	MHz	Fundamental
2	Frequency tolerance	f <sub>tol</sub>	±10	x10 <sup>-6</sup>	CL = 8 pF Ta = +25 °C ±3 °C DL = 100 uW Not include aging
3	Motional resistance	R <sub>1</sub>	60 Max.	Ω	π circuit IEC 60444-2 T <sub>use</sub> = Operating temperature range DL : 100 uW
4	Shunt capacitance	C <sub>0</sub>	3 Max.	pF	π circuit and N.A.
5	Frequency versus temperature characteristics	f <sub>tem</sub>	±20	x10 <sup>-6</sup>	T <sub>use</sub> = Operating temperature range Ref. at +25 °C ±3 °C DL : 100 uW
6	Isolation resistance	IR	500 Max.	MΩ	DC 100 V, 60 seconds between each terminals ( #1, #3 )
7	Aging	f <sub>age</sub>	±3	x10 <sup>-6</sup> / year	Ta = +25 °C ±3 °C DL : 100 uW

#### [ 4 ] Environmental and mechanical characteristics

(The company evaluation condition : We evaluate it by the following examination item and examination condition.)

No.	Item	Value *1 *2		Test Conditions
		$\Delta f / f [1 \times 10^{-6}]$		
1	Drop	*3	$\pm 3$	150 g dummy Jig (Seiko Epson Standard) drop from 1500 mm height on the Concrete 6 directions 10 times
2	Vibration	*3	$\pm 3$	10Hz~40Hz 1.5mm 40Hz~2000Hz 5G (1cycle = 20min) x 12cycle x3direction.
3	High temperature storage	*3	$\pm 5$	+125 °C x 1 000 h
4	Low temperature storage	*3	$\pm 3$	-40 °C x 1 000 h
5	Temperature cycle	*3	$\pm 3$	-40 °C ↔ +125 °C 30 minutes at each temp. 1000 cycle
6	Temperature humidity storage	*3	$\pm 3$	+85 °C x 85 %RH x 1 000 h
7	Resistance to soldering heat		$\pm 3$	For convention reflow soldering furnace (3times)
8	Substrate bending	No peeling-off at a soldered part		Bend width reaches 2 mm and hold for 60 s $\pm 1$ s x 1 time Ref. IEC 60068-2-21
9	Shear	No peeling-off at a soldered part		10 N press for 10 s $\pm 1$ s Ref. IEC 60068-2-21
10	Pull – off	No peeling-off at a soldered part		10 N press for 10 s $\pm 1$ s Ref. IEC 60068-2-21
11	Solder ability	Terminals must be 95 % covered With fresh solder.		Dip termination into solder bath at +235 °C $\pm 5$ °C for 5 s (Using Rosin Flux)

< Notes >

- \*1 each test done independently.
- \*2 measuring 2 h to 24 h later leaving in room temperature after each test.
- \*3 Measuring 24 h later leaving in room temperature after each test.
  - Reflow 3 times
  - Initial value shall be after 24h at room temperature.
- Shift series resistance at before above tests should be less than  $\pm 20$  % or less than  $\pm 10$   $\Omega$ .

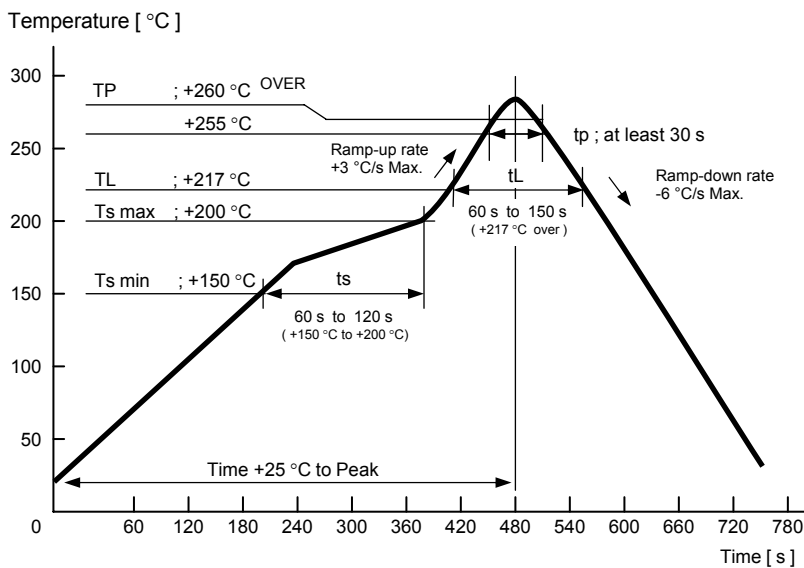

# [ 5 ]Dimensions and Circuit

1) Dimension (Unit : mm)

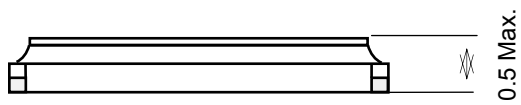
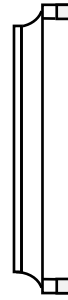
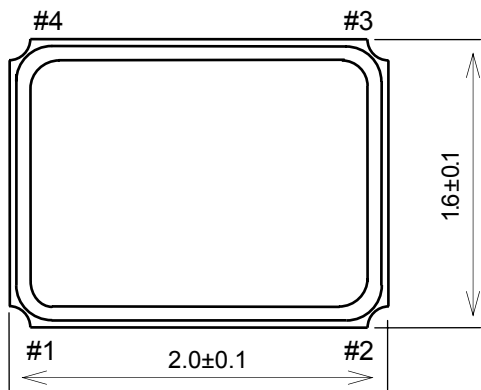

Internal connection

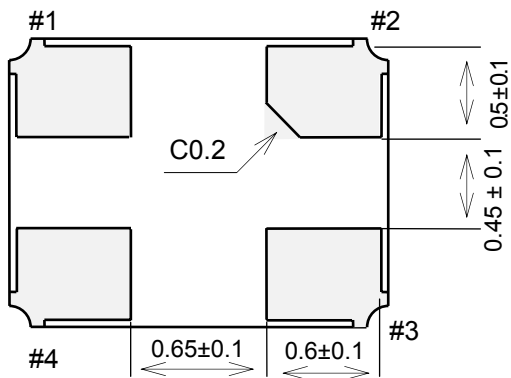

TOP VIEW

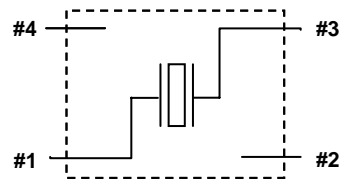

Terminal #2, #4 are connected to the LID  
 (Please connect GND)  
 Terminal treatment : Au plate

[ 6 ] Recommended soldering pattern and Marking layout

1. Recommended soldering pattern (Unit : mm)

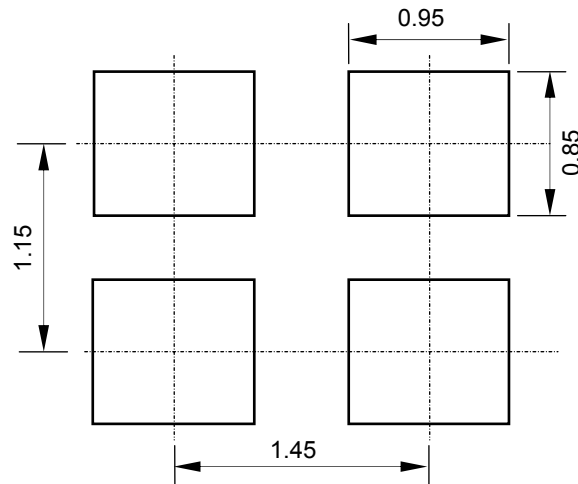

2. Marking layout.

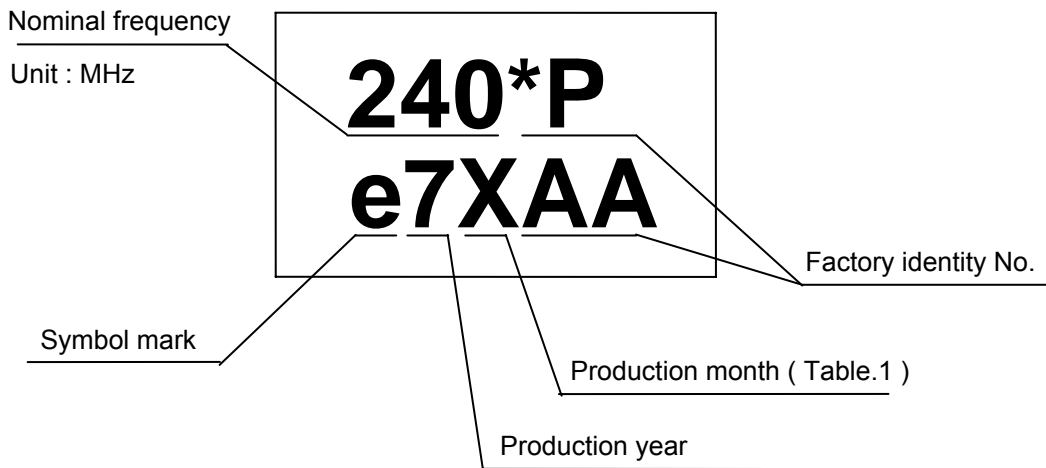

Table.1 Production month

Production Month	Jan.	Feb.	Mar.	...	Oct.	Nov.	Dec.
Marking	1	2	3	...	X	Y	Z

\* Nominal frequency is only one example.

\* Nominal frequency is display to the first decimal place.

ex) 24 MHz ..... [240]

\* The above marking layout shows only marking contents and their approximate position and it is not for font, size and exact position.

## [ 7 ] Notes

1. Max three (3) times re-flow is allowed. Its recommended to manually solder when not enough/no solder detected.( Using soldering iron at +350 °C × within 5 seconds)
2. Patterning on a board should follow our company recommended pattern.
3. Applying excessive excitation force to the crystal unit may cause deterioration damage.
4. Start up time of oscillation may be increased or no oscillation may occur unless adequate negative resistance is allocated in the oscillation circuit In order to avoid this, please provide enough negative resistance to the circuit design.

How to check the negative resistance

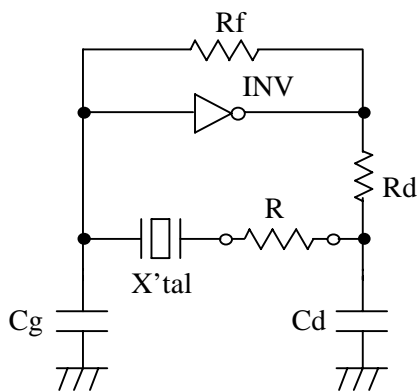

- (1) Connect the resistor(R) to the circuit in series with the crystal unit.
- (2) Adjust R so that oscillation can start (or stop).
- (3) Measure R when oscillation just start (or stop) in above (2).
- (4) Get the negative resistance  
 $-R=R+CI$  value.
- (5) Recommended  $-R$   
 $[-R]>CI \times 10$

5. It is recommended to do patterning to the oscillator as short as possible. Abnormal oscillation may happened if the line is too long.
6. To avoid malfunction, no pattern across or near the crystal unit is allowed.
7. Few data or readings taken at user side may be different from our company's data. Confirmation of the different value is necessary before application.
8. Too much exciting shock or vibration may cause deterioration on damage.  
 The product may damage depends on the condition such as a shock in assembly machinery.  
 Please check your process condition in advance to minimize and maintain the shock level.
9. This product may be affected to ultrasonic cleaning. It is depends on the cleaning conditions (Cleaning machine type/power/time/content/position etc.). The warranty will not cover any damage due to this type of usage. Check conditions prior to use.
10. Condensation may occur when used/stored under high humidity condition.  
 Please take precautions to prevent condensation.
11. Please refer to packing specification for the storage method and packing standard.