

RECIPIENT

SPECIFICATIONS

Product No. : X1E0003710004**

MODEL : FA2016AS

SPEC. No. : A16-773-0B

DATE : Mar. 7. 2017

△ Mar. 18. 2020

**	Quantity
00	3 000 pcs
01	Vinyl Bag(Bulk)
11	Any Quantity
12	250 pcs
14	1 000 pcs
18	5 000 pcs

SEIKO EPSON CORPORATION

8548 Naka-minowa
Minowa-machi Kamiina-gun
Nagano-ken
399-4696 Japan

CHECKED K. Yamanaka / TD Engineering Department Manager
Kunihito Yamanaka

CHECKED J. Nishide / TD Production Engineering Department Senior Staff
Jun Nishide

CHECKED Y. Kurahashi / TD • CS Quality Assurance Department Manager
Yoshitaka Kurahashi

PREPARED Emi Oguchi / TD • CS Quality Assurance Department Staff
Emi Oguchi

Update History

No.	Date	Page	Item	Current	Update
①	Sep.6.2019	Cover	Product No. X1E0003710004**	** code 00 - 3000 pcs 01 - Vinyl bag (Bulk) 11 - Any Quantity 12 - 250 pcs 14 - 1000 pcs	** code 00 - 3000 pcs 01 - Vinyl bag (Bulk) 11 - Any Quantity 12 - 250 pcs 14 - 1000 pcs 18 - 5000 pcs
		TAPING SPECIFICATION	TAPING SPECIFICATION	-	Added
		Process Quality Control	Process Quality Control	-	Added
		Structure Diagram	Structure Diagram	-	Added
		RELIABILITY TEST DATA	RELIABILITY TEST DATA	-	Added
②	Mat.18.2020	P.2	[1] 38.4 MHz Crystal Specifications Tolerance over temperature	-	[Notes] the Drive level test conditions 10uW for the initial frequency tolerance specs (Added)
			Equivalent series resistance	80 Ω Max.	50 Ω Max.
		P.3	Table 2 Specification for DLD measurement of the crystal Drive level dependency	Max. – Min. < 3×10^{-6} [Condition] 0.01 μW to 100 μW to 0.01 μW	< 6×10^{-6} 0.01 μW to 200 μW to 0.01 μW
			P.4	[2] GPS Quality Specifications Residual frequency stability slope (residual = difference from fifth-order curve fit)*	[Condition] Ta = -30 °C to +85 °C
		[Specification] ±50 (Max.)		±100 (Max.) ±50 (Max.) ±100 (Max.)	
		~1.0 °C/min		~1.0 °C/minute	

SPECIFICATIONS

1. Application

- 1) This document is applicable to the crystal unit that is delivered to QUALCOMM, INC from Seiko Epson Corp.
- 2) RoHS compliant
FA2016AS contains lead in Low melting type solder which is exempted in RoHS directive.
- 3) This Product supplied (and any technical information furnished, if any) by Seiko Epson Corporation shall not be used for the development and manufacture of weapon of mass destruction or for other military purposes. Making available such products and technology to any third party who may use such products or technologies for the said purposes are also prohibited.
- 4) This product listed here is designed as components or parts for electronics equipment in general consumer use. We do not expect that any of these products would be incorporated or otherwise used as a component or part for the equipment, which requires an systems, and medical equipment, the functional purpose of which is to keep extra high reliability, such as satellite, rocket and other space life.

2. Product No. / Model

The product No. of this crystal unit is X1E000371000400.
The model is FA2016AS.

3. Packing

It is subject to the packing standard of Seiko Epson Corp.

4. Warranty

Defective parts which originate with us are replaced free of charge in the case of defects being found with 12 months after delivery.

5. Amendment and/or termination

Amendment and/or termination of this specification is subject to the agreement between the two parties.

6. Contents

Item No.	Item	Page
[1]	38.4 MHz Crystal specification	2-3
[2]	GPS Qualification	3-7
[3]	Thermistor Specifications	7
[4]	Environmental and mechanical characteristics	8
[5]	Dimensions and circuit	9
[6]	Recommended soldering pattern and marking layout	10
[7]	Notes	11

[1] 38.4 MHz Crystal Specifications

■ Standard 4-pin crystal footprint with the crystal connected between pins 1 and 3

Table 1 38.4 MHz 2016 package size crystal specifications

Parameter	Min	Nom	Max	Units	Notes
Operating frequency		38.4		MHz	
Mode of vibration		AT-cut fundamental			
Initial frequency tolerance			±10	× 10 ⁻⁶	Frequency tolerance: 25 °C ±3 °C the Drive level test conditions 10uW for the initial frequency tolerance specs
Tolerance over temperature			±12	× 10 ⁻⁶	-30 °C to +85 °C; above +85 °C tolerance over temperature bound by the third-order coefficient range in Section A.5
Aging			±0.7	×10 ⁻⁶ /year	
Frequency drift after reflow			±2	× 10 ⁻⁶	After two reflows
Operating temperature	-30		+105	°C	
Storage temperature	-40		+105	°C	
Equivalent series resistance			50	Ω	Minimum Q, drives a smaller ESR, i.e., design the crystal to the minimum Q
Quality factor (Q)	75000				The minimum Q value calculated from ESR and L is smaller than this specification.
Spurious mode series resistance	1100			Ω	± 1 MHz
Pullability	7		16	× 10 ⁻⁶ /pF	
Load capacitance		8		pF	The load capacitance is measured according to IEC Standard #60444-7.
Inflection point	27.5		30.5	°C	$t = (t_0 - \frac{C2}{3C3})$
C1, first-order curve fitting parameter Refer to the Curve Fit Calculation Table Spreadsheet(80-V9690-23)	-0.40		-0.10	× 10 ⁻⁶ /°C	The curve fitting parameter is obtained from the Qualcomm crystal curve fitting algorithm using the temperature inflection point t0 = 29 °C.
C2, second-order curve fitting parameter Refer to the Curve Fit Calculation Table Spreadsheet(80-V9690-23)	-4.5	0	4.5	×10 ⁻⁴ × 10 ⁻⁶ /°C ²	The curve fitting parameter is obtained from the Qualcomm crystal curve fitting algorithm using the temperature inflection point t0 = 29 °C.
C3, third-order curve fitting parameter Refer to the Curve Fit Calculation Table Spreadsheet(80-V9690-23)	8.5	10	11.5	×10 ⁻⁵ × 10 ⁻⁶ /C ³	The curve fitting parameter is obtained from the Qualcomm crystal curve fitting algorithm using the temperature inflection point t0 = 29 °C.
Drive level	1		200	μW	
Insulation resistance	500			MΩ	
Package		2.0 × 1.6		mm ²	

Table 2 Specification for DLD measurement of the crystal \triangle

	Item	Max. – Min.	Repeatability	Condition
Drive level dependency	Freq	$< 6 \times 10^{-6}$	$< 0.7 \times 10^{-6}$	0.01 μ W to 200 μ W to 0.01 μ W
	ESR	$< 20 \%$	$< 10 \%$	

Notes:

1. Number of points: 15 points up and 15 points down = 29 total data points.
2. Max - min: Difference between the maximum and minimum in a two-way measurement. For ESR, the change rate is $(\text{max} - \text{min})/\text{min} < 20\%$.
3. Repeatability: Repeatability of two-way measurement in the above condition. For ESR, the change rate is $(\text{ESR2} - \text{ESR1})/\text{ESR1} < 10\%$.
4. ESR1: First measurement on each drive level.
5. ESR2: Second measurement on each drive level; for example, how to specify each parameter.

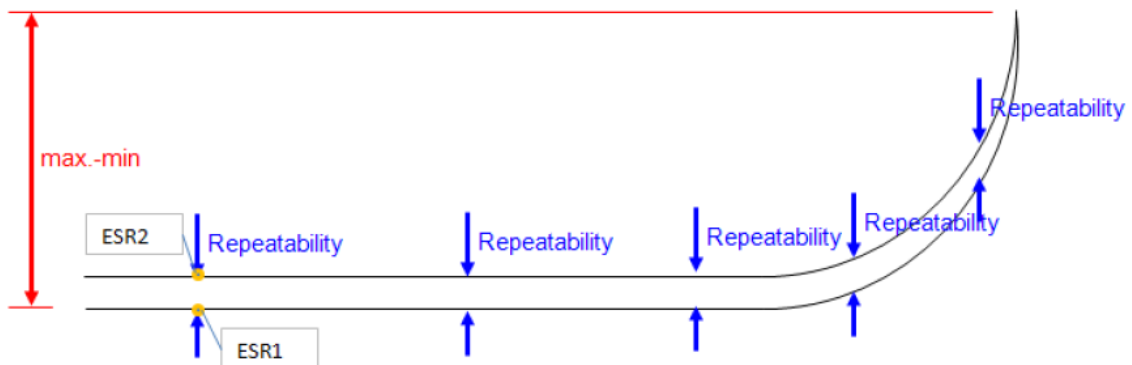

Figure 1 Crystal perturbation specification 3 (DLD testing requirements)

6. Test instructions for DLD measurement of the crystal:
 - DLD testing should be done on every device to detect fabrication issues such as contamination, particles of dust, and so on, and to verify proper crystal functionality.

[2] GPS Quality Specifications \triangle

Table 3 Crystal perturbation specification 1 (residual frequency stability slope)

Item	Condition	Specification	Unit
Residual frequency stability slope (residual = difference from fifth-order curve fit)*	Ta = -30 °C to -15 °C	± 100 (Max.)	ppb/°C
	Ta = -15 °C to +70 °C	± 50 (Max.)	
	Ta = +70 °C to +85 °C	± 100 (Max.)	
5 °C small orbit hysteresis 1*	Ta = -30 °C to +85 °C	± 50 (Max.)	ppb/°C

* Must meet the 1A and 1B conditions:

- Condition 1A – Test condition (continuous temperature rate change of ~1.0 °C/minute):
 - Measure FT points every 1 °C, heating up from -30 °C to +85 °C, subtract a fifth-order polynomial best fit and then calculate the slope of the residual.
 - The residual slope should be within ±50 ppb/°C.
- Condition 1B – Hysteresis 1 test condition (continuous temperature rate change of ~1.0 °C/minute):
 - Measure FT points every 0.5 °C while cycling temperature over a 5 °C small temperature orbit; an example 5 °C small orbit temperature cycle is +30 °C to +35 °C to +30 °C.
 - During every individual heating/cooling cycle there should be 11 points; discard the first point of each heating and cooling cycle; this leaves 10 points for each heating and cooling cycle. Subtract the fifth-order polynomial best fit from 1 A for each of the 10 points, and then calculate the slope of the residual for each of these heating and cooling 10 point curves.
 - The residual slope should be within ±50 ppb/°C.

Table 4 Crystal perturbation specification 2 (small orbit hysteresis 2)

Item	Condition	Specification	Unit
5 °C small orbit hysteresis 2**	Ta = -30 °C to +85 °C	100 (magnitude)	ppb pk-pk

** Must meet condition 2:

- Condition 2 – Hysteresis 2 test condition (continuous temperature rate change of ~1.0 °C/minute):
 - Measure FT points every 0.5 °C while cycling temperature over a 5 °C small temperature orbit; an example 5 °C small orbit temperature cycle is +30 °C to +35 °C to +30 °C.
 - During every individual heating/cooling cycle there should be 11 points; discard the first and last point of each heating and cooling cycle, which results in nine temperature points. Calculate the average measured peak-to-peak frequency difference for these nine temperature points.
 - The average difference is the magnitude of the small orbit hysteresis 2.

GPS Test instructions and purpose of these tests/specifications

1. Testing:

- DLD testing should be done on every device to detect fabrication issues such as contamination, particles of dust, etc., and to verify proper crystal functionality.
- Specifications 1A, 1B, and 2 process control confirmation testing is recommended to be done at a minimum on a sampling basis for every lot.

2. The purpose of the specifications:

- Specification 1A:
 - Verify that the FT curve can fit with a fifth-order polynomial.
 - Verify that there are no package resonances and no micro-jumps that exceed the residual frequency stability slope specification.
 - See Figure 2.
- Specification 1B:
 - Verify that the small orbit hysteresis 1 is controlled to less than 50 ppb/°C residual slope in the crystal (departure from FT curve over small orbits).
 - See Figure 3.
- Specification 2:
 - Verify that hysteresis 2 (the gap between the cooling and heating FT curves) over small orbits is of a reasonable value.
 - These are the rapid shifts that occur when changing from cooling-to-heating or heating-to-cooling.
 - See Figure 4.

3. Measurement technique for specifications 1 and 2:

- Standard thermocouple should not be used since it has a 0.1 °C temperature resolution and therefore can fail a 50 ppb/°C test due to measurement quantization (i.e., which is not part of the real crystal FT performance curve).
- A preferable technique to measure temperature is to use the internal thermistor (or an external thermistor located near crystal on the PCB board). As an example, voltage measurement is a feature of the 34970A Data Acquisition Unit from Agilent. Frequency can be measured via the 53131A_132A 225 MHz Agilent frequency counter.
- A continuous temperature rate change of ~1.0 °C/minute is recommended for all tests.

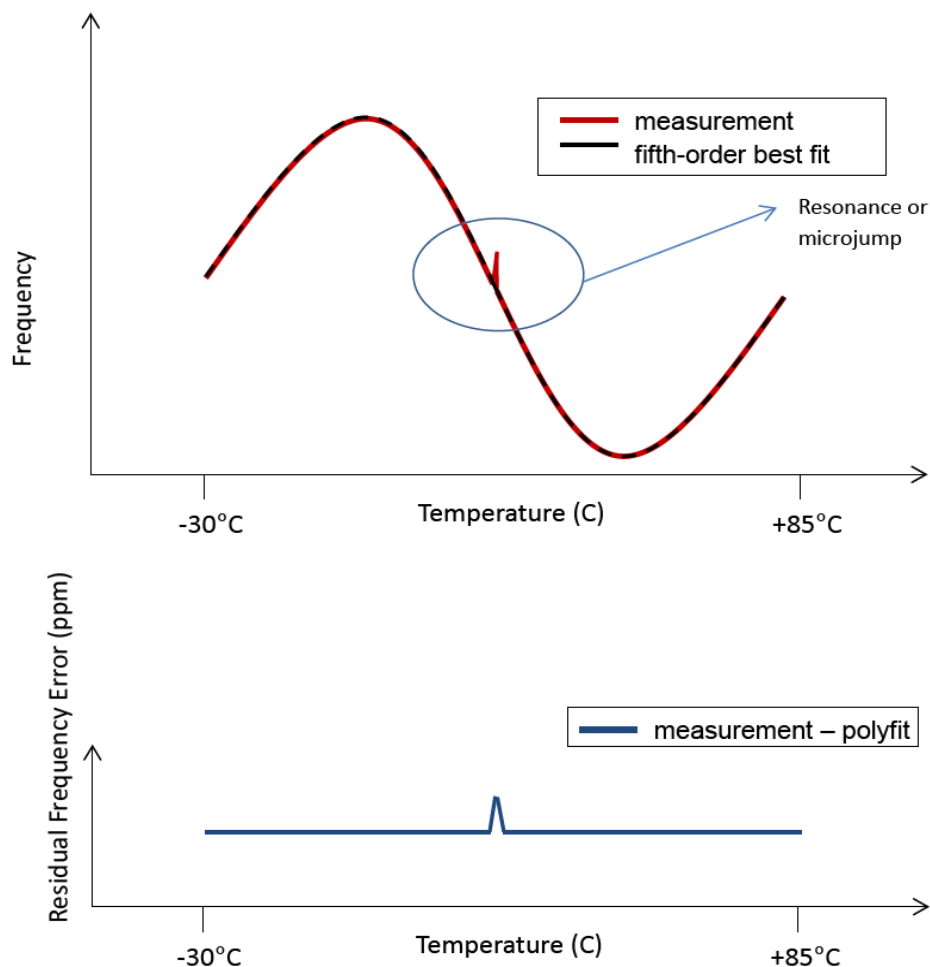

Figure 2 Measurement to locate resonances or micro-jumps

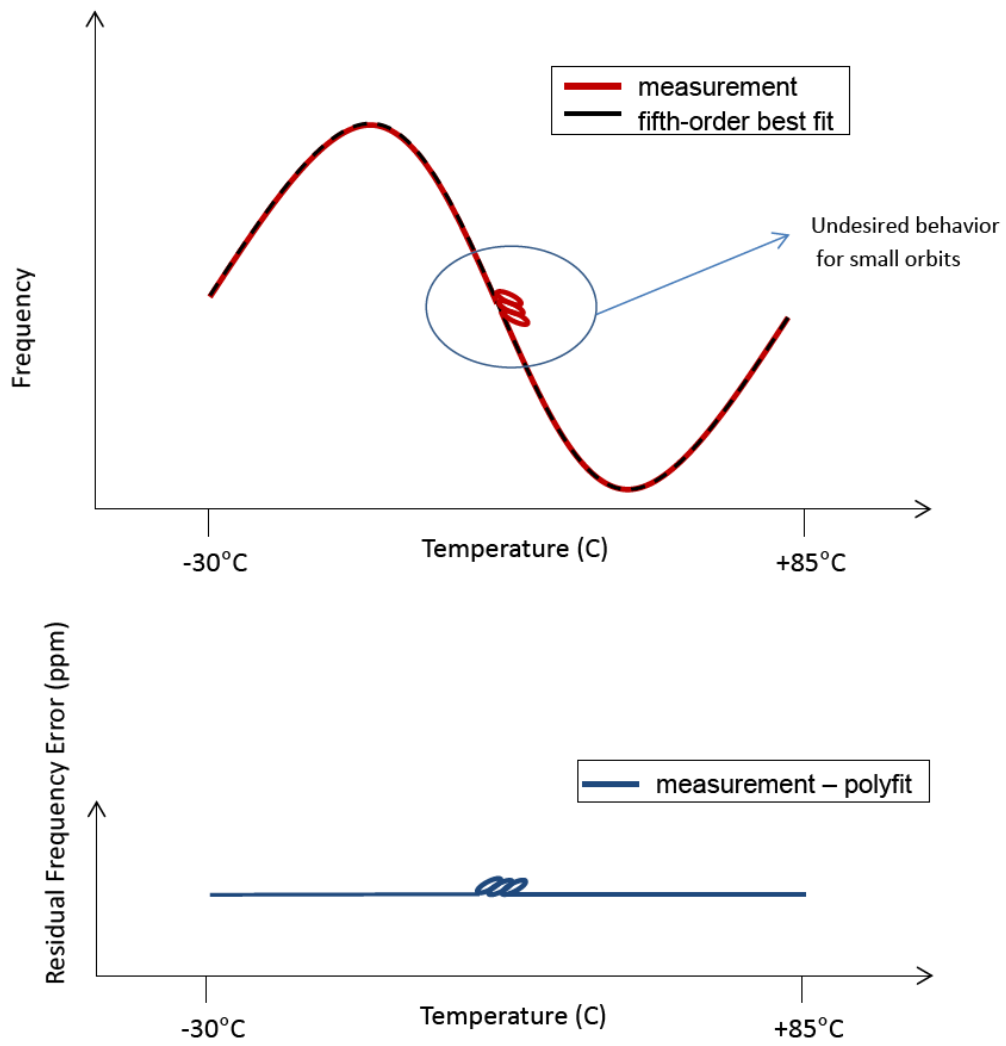

Figure 3 Measurement to locate small orbit hysteresis 1

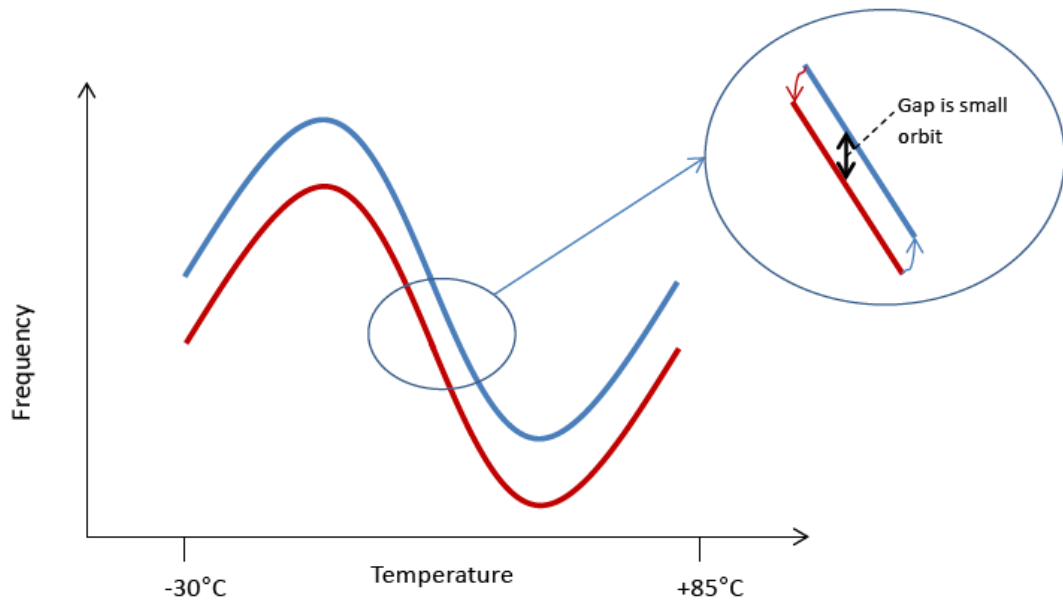

Figure 4 Measurement to locate hysteresis 2

[3] Thermistor Specifications

Table 5 Thermistor specifications

Parameter	Min.	Nom	Max.	Units	Notes
Operating temperature	-30		+105	°C	
Storage temperature	-40		+105	°C	
Resistance		100		kΩ	25°C
B-constant		4250		K	25°C–50°C
Tolerance			1	%	

[4] Environmental and mechanical characteristics

Item No.3 to No.6 shall be tested after following pre conditioning.

Pre conditioning : Test crystal must be leaving in room temperature for 24 h after reflow × 3.

(The company evaluation condition : We evaluate it by the following examination item and examination condition.)

No.	Item	Value *1 *2		Test Conditions
		(1)	(2)	
1	Drop	(2)	±2	150 g dummy Jig (SE Standard) drop from 1 500 mm height on the Concrete 3 directions 10 times
2	Vibration	(2)	±2	10 Hz to 55 Hz amplitude 0.75 mm 55 Hz to 500 Hz acceleration 98 m/s ² 10 Hz → 500 Hz → 10 Hz 15 min /cycle 6 h (2 hours , 3 directions)
3	High temperature storage	(1)	±2	+85 °C × 1 000 h
4	Low temperature storage	(1)	±2	-40 °C × 1 000 h
5	Temperature cycle	(1)	±2	-40 °C ↔ +125 °C 30 minutes at each temp. 100 cycle
6	Temperature humidity storage	(1)	±2	+85 °C × 85 %RH × 1 000 h
7	Resistance to soldering heat		±2	For convention reflow soldering furnace (3 times)
8	Substrate bending	No peeling-off at a soldered part		Bend width reaches 3 mm and hold for 5 s ±1 s × 1 time Ref. IEC 60068-2-21
9	Shear	No peeling-off at a soldered part		10 N press for 10 s ±1 s Ref. IEC 60068-2-21
10	Pull – off	No peeling-off at a soldered part		10 N press for 10 s ±1 s Ref. IEC 60068-2-21
11	Solder ability	Terminals must be 95 % covered With fresh solder.		Dip termination into solder bath at +230 °C ±10 °C for 5 s (Using Rosin Flux)

< Notes >

- Item No.1 to No.7 resistance at before above tests should be less than ±20 % or less than ±10 Ω.
- *1 Each test done independently.
- *2 Measuring 2 h to 24 h later leaving in room temperature after each test.
 - Measuring 24 h later leaving in room temperature after each test.
 - Measuring 2 h later leaving in room temperature after each test.

Reflow condition (follow to IPC / JEDEC J-STD-020D.1)

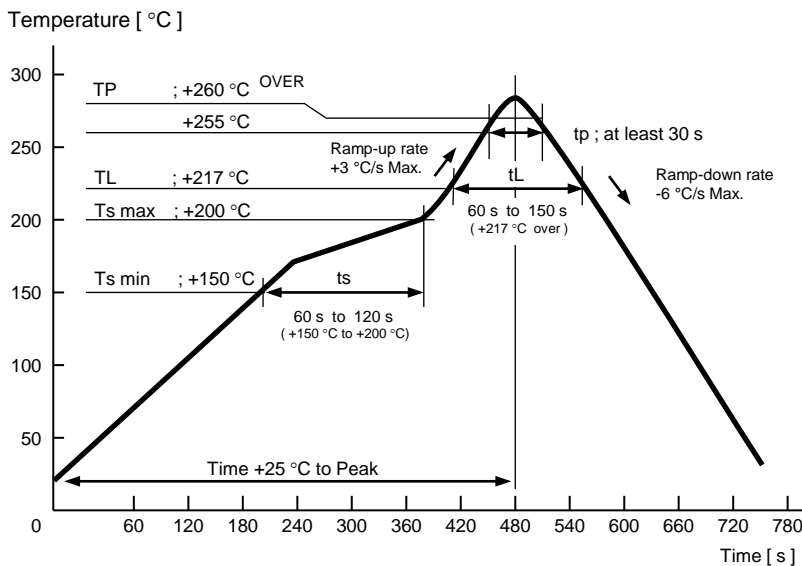

[5] Dimensions and Circuit

1) Dimension (Unit : mm)

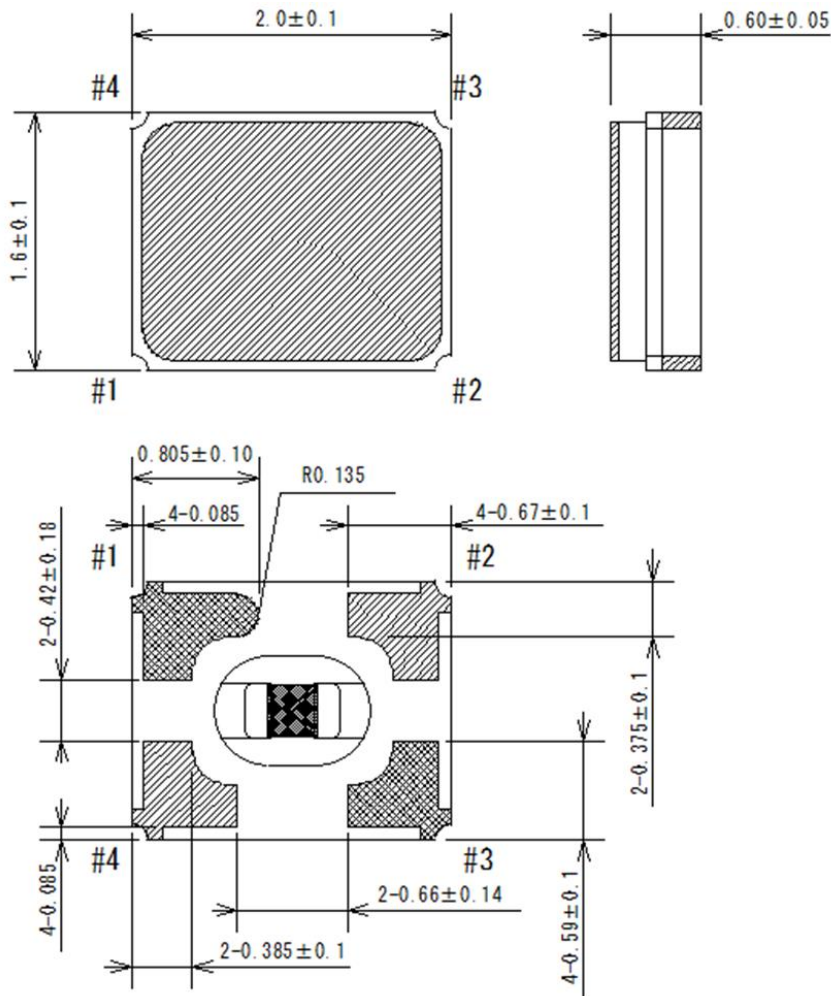

2) Circuit

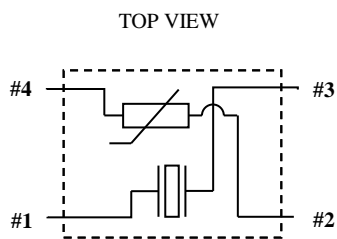

Terminal treatment : Au plate

Pin	Connection
1	XTAL
2	GND, thermistor
3	XTAL
4	Thermistor

Thermistor size : 0.6×0.3

[6] Recommended soldering pattern and Marking layout

1) Recommended soldering pattern (Unit : mm)

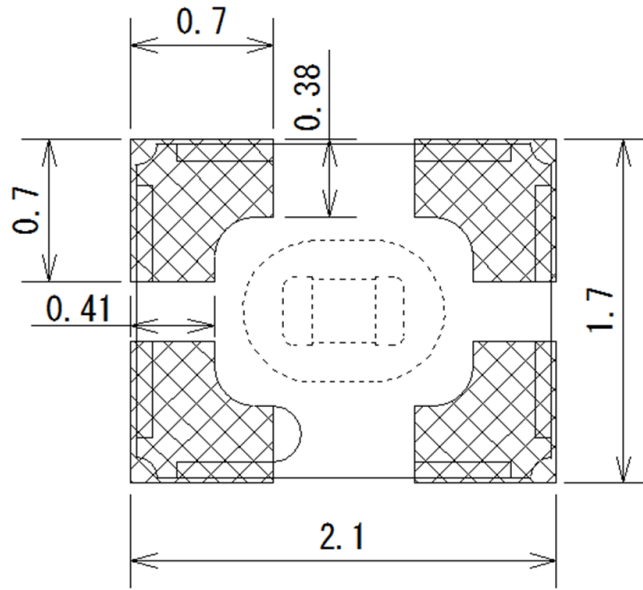

2) Marking layout

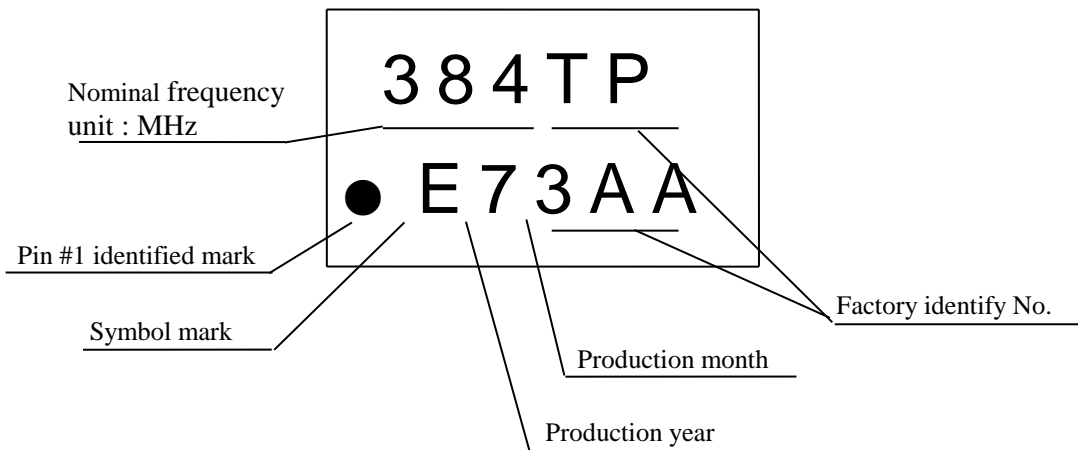

Production month

January	February	October	November	December
1	2	X	Y	Z

- Nominal frequency is only one example.
- Nominal frequency omits the figure below the first place of decimals.
Ex) 38.4 MHz..... [384]
- The above marking layout shows only marking contents and their approximate position and it is not for font, size and exact position.

[7] Notes

1. Max three (3) times re-flow is allowed. Its recommended to manually solder when not enough/no solder detected.
(Using soldering iron at +280 °C Max. × within 5 seconds)
2. Patterning on a board should follow our company recommended pattern.
3. Applying excessive excitation force to the crystal resonator may cause deterioration damage.
4. Start up time of oscillation may be increased or no oscillation may occur unless adequate negative resistance is allocated in the oscillation circuit In order to avoid this, please provide enough negative resistance to the circuit design.

How to check the negative resistance

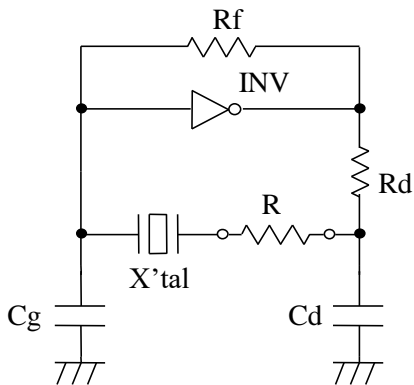

- (1) Connect the resistor(R) to the circuit in series with the crystal Unit.
- (2) Adjust R so that oscillation can start (or stop).
- (3) Measure R when oscillation just start (or stop) in above (2).
- (4) Get the negative resistance
 $-R=R+CI$ value.
- (5) Recommended $-R$
 $[-R]>CI \times 5$

5. It is recommended to do patterning to the oscillator as short as possible. Abnormal oscillation may happened if the line is too long.
6. To avoid malfunction, no pattern across or near the crystal is allowed.
7. Few data or readings taken at user side may be different from our company's data. Confirmation of the different value is necessary before application.
8. Too much exciting shock or vibration may cause deterioration on damage.
The product may damage depends on the condition such as a shock in assembly machinery.
Please check your process condition in advance to minimize and maintain the shock level.
9. This product may be affected to ultrasonic cleaning. It is depends on the cleaning conditions.
(Cleaning machine type/power/time/content/position etc.)
The warranty will not cover any damage due to this type of usage. Check conditions prior to use.
10. Condensation may occur when used/stored under high humidity condition.
Please take precautions to prevent condensation.
11. Please refer to packing specification for the storage method and packing standard.

TAPING SPECIFICATION



テープ梱包基準書

1. APPLICATION 適用範囲

This document is applicable to FA2016AS

本基準書は、FA2016AS のテーピング梱包について規定する。

2. CONTENTS 目次

Item No.	Item	Page
[1]	Taping specification テーピング仕様	2 to 3
[2]	Shipping carton 外装箱への収納	4
[3]	Marking 表示	
[4]	Quantity 収納数量	
[5]	Storage environment 保管環境	5
[6]	Handling リール取扱い	

[1] Taping specification テーピング仕様

Subject to EIA-481, IEC 60286, JIS C0806.

「EIA-481」「IEC 60286」「JIS C0806」に準拠する。

(1) Tape dimensions TE0804L

Material of the Carrier Tape キャリアテープ材質: PS

Material of the Top Tape トップテープ材質 : PET+PE

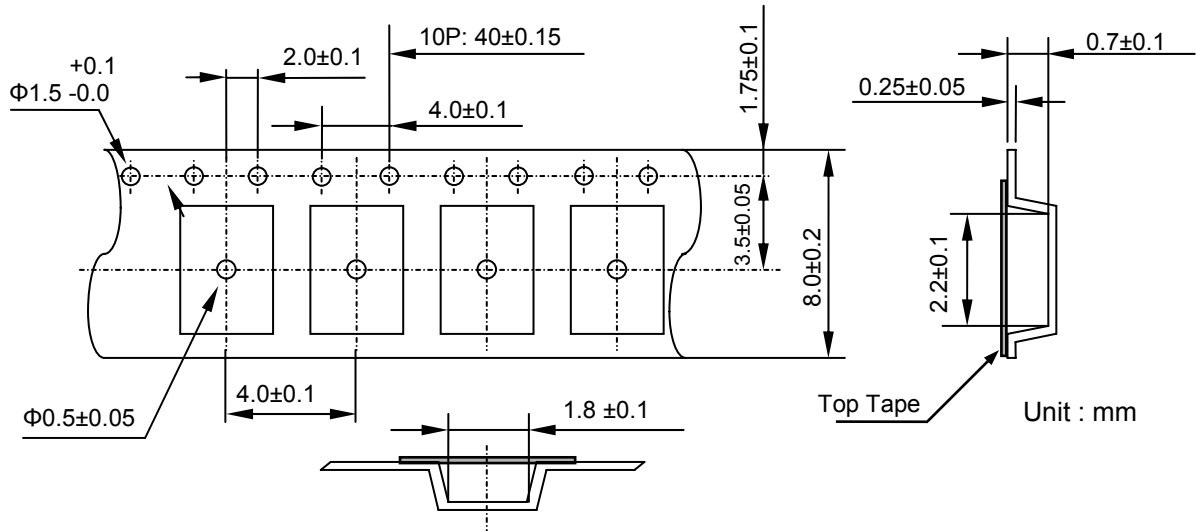

* Inner curve of each corner 0.25 mm Max.
各コーナーの内Rは0.25 Max.

(2) Reel dimensions

EIAJ-RRM08B60

(a) Center material 中心材質 : PS

(b) Material of the Reel リール材質: PS

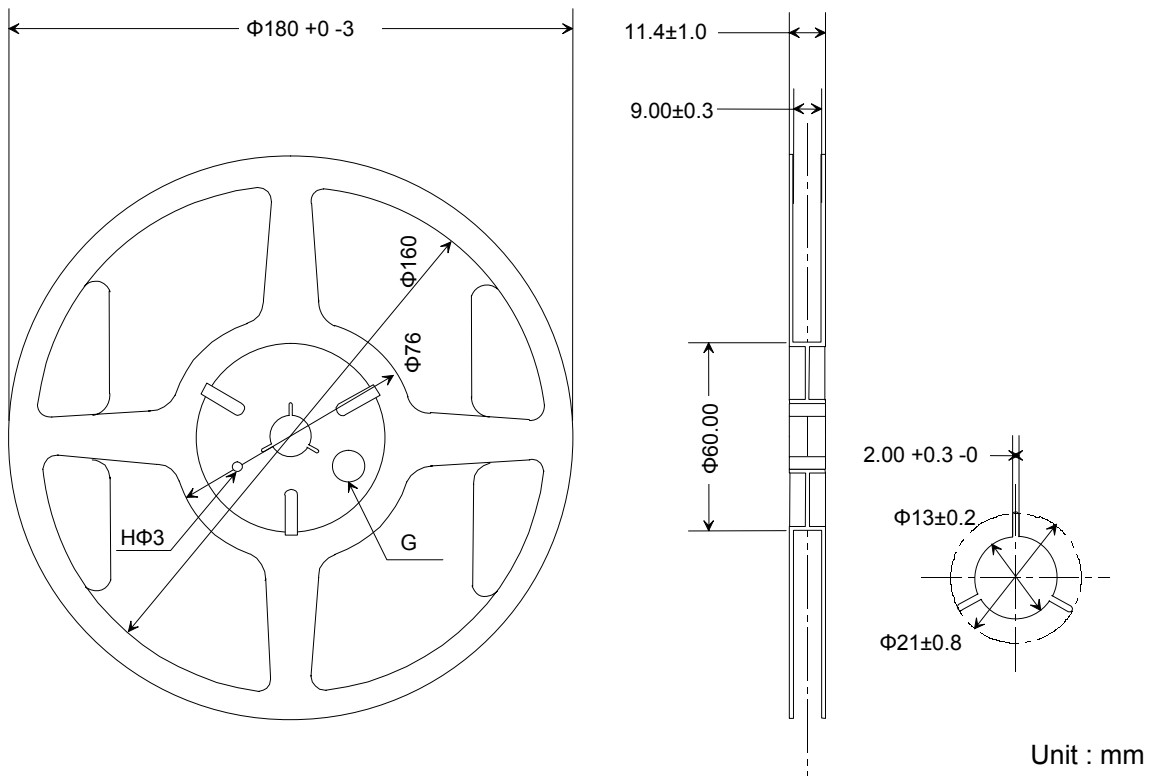

(3) Packing 収納形態
 (a) Tape & Reel デバイス収納方法

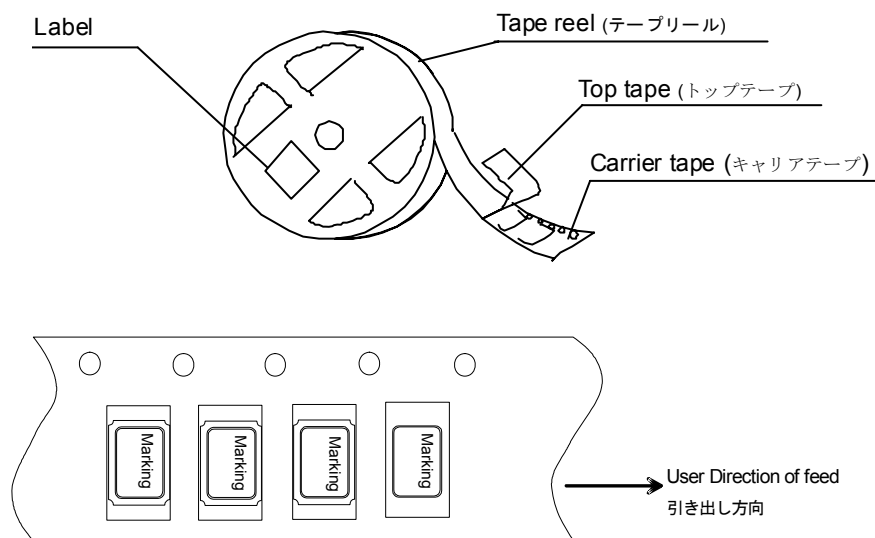

(b) Start & End Point 引き出し先頭側及びリール側の処理

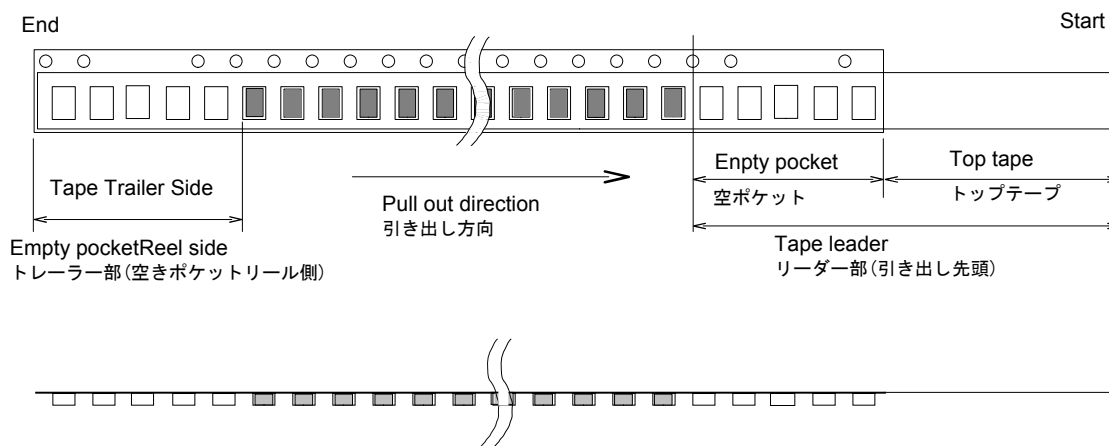

Item 項目		Empty Space 空きスペース	Note 備考
Tape Leader (引き出し先頭側)	Top Tape	Min. 1 000 mm	Feeding in the Top tape, the tip is fixed with tape. トップテープ単独で繰り出し、先端はテープにより固定。
	Carrier Tape	Min. 100 mm	Winding method is a diagram of the above リールへの巻き取り方法は、上図の通り。
Tape Trailer (リール側)	Top Tape	Min. 0 mm	Tip is fixed to the reel. 先端はリールに固定。
	Carrier Tape	Min. 160 mm	

(4) Peel force of the cover tape トップテープの剥離強度

(a) angle : cover tape during peel off and the direction of unreeling shall be 165° to 180°.

剥離角度 : テープの接着面に対し 165~180 度とする。

(b) peel speed : 300 mm/min

剥離速度 : 300 mm/min とする。

(c) peel strength : 0.1~1.0 N

剥離強度 : 0.1~1.0 N

[2] Shipping carton 外装箱への収納

a) Packing to antistatic bag 袋への収納

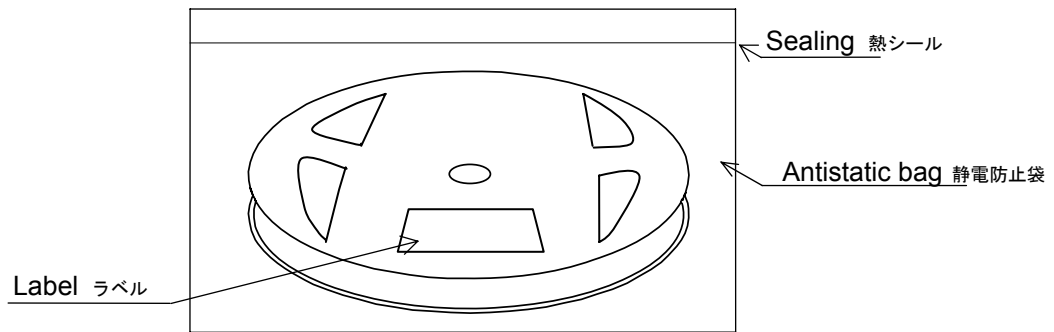

b) Packing to shipping carton 外装箱への収納

If there is space in the outer box, material is put in a shock absorbing together.
空間ができた時は、クッション材を入れる。

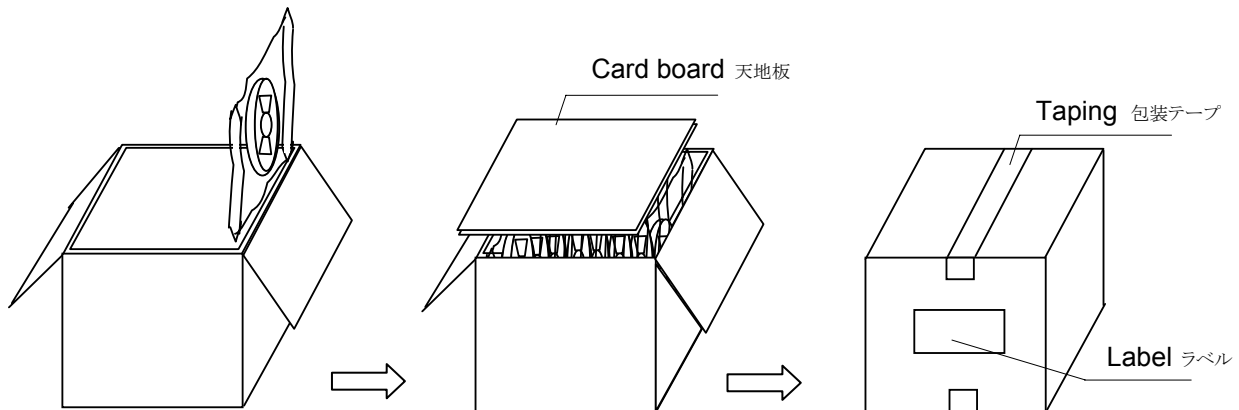

[3] Marking 表示

(1) Reel marking リールへの表示

● Reel marking shall consist of

下記内容をリール表面に表示できるラベルを貼る。:

- 1) Parts name 製品名称
- 2) Quantity 製品数量
- 3) Manufacturing Date or symbol 製品の製造年月又はこれを示す記号
- 4) Manufacturer's Date or symbol 製品の製造業者又はその略号
- 5) Others (if necessary) その他必要事項

(2) Shipping carton marking 外装箱への表示

● Shipping carton marking shall consist of :

下記内容を外装箱表面に表示できるラベルを貼る。:

- 1) Parts name 製品名称
- 2) Quantity 製品数量

[4] Quantity 収納数量

- 3 000 pcs./reel (Standard)

However it is not the limit, in case that the order quantity does not fill with 3 000 pieces.
Packing quantity is defined by 14th and 15th digit of product number.

但し、注文数量が 3 000 pcs に満たない場合は、その限りではない。
収納数量は、製品型番の 14 桁、15 桁による。

14th and 15th digit of product number. 製品型番の 14 桁、15 桁	Quantity
00	3 000 pcs
01	Vinyl Bag(Bulk)
11	Any Quantity
12	250 pcs
14	1000 pcs
18	5000 pcs

[5] Storage environment 保管環境

- (1) Before open the packing, we recommend to keep less than +30 °C and 85 %RH of Humidity, and to use it less than 6 months after delivery.

開梱前の製品は、温度 +30 °C、湿度 85 %RH 以下での保管をして下さい。
貴社納入後、袋未開封で 6 ヶ月以内の実装を推奨します。

- (2) We recommend to open Package in immediately before use. After open Package, We recommend to keeps less than 6 month. No need dry air before soldering work if it is less than temperature +30 °C, 85 humidity %RH.

使用直前まで開梱せず、袋開封後は 6 ヶ月以内の実装を推奨します。
温度 +30 °C、湿度 85 %RH 以下では、はんだ付け作業前に乾燥不要です。

- (3) Not to storage with some erosive chemicals.

化学薬品類との同居を避ける。

- (4) Nothing is allowed to put on the reel or carton to prevent mechanical damage

外装箱がゆがまないようまた、外圧がかからないように保管して下さい。

[6] Handling リール取扱い

To handle with care to prevent the damage of tape, reel and products.

リールの取扱いについては、中のテープ・製品を变形させないようにして下さい。



SMD TYPE CRYSTAL UNIT : FA2016AS (Crystal+Thermistor)

Manufacturing Process Chart		No.	Section	Standard	Inspection, Control items	Inspection method	Instrument	Record
<p>Crystal block</p> <p>1' In-coming inspection</p> <p>2 Wafer cutting</p> <p>3 Wafer lapping</p> <p>4 Photo process</p> <p>5 Mounting</p> <p>6 Frequency adjustment</p> <p>7 Welding</p> <p>8 Leak test</p> <p>9 Marking</p> <p>10 Characteristic inspection 1</p> <p>11 Thermistor Mounting</p> <p>12 Characteristic inspection 2</p> <p>13 Out-going inspection</p> <p>14 Taping</p> <p>15 Packing</p> <p>Ceramic base</p> <p>Lid</p> <p>Thermistor</p>	1	Inspecting section.	Purchasing specification Incoming inspection standard	Size. Outer appearance. Inner appearance.	Sampling. " "	Measure. Visual inspection. Visual inspection.	In-coming inspection data sheet.	
	1'	Inspecting section.	"	Size. Outer appearance.	Sampling. "	Comparator. Micro scope.	"	
	2	Inspecting section.	Manufacturing instruction sheet	Cut angle. Wafer thickness.	Sampling. "	X-ray radio graphic. Comparator.	Process data sheet.	
	3	Producing section.	"	Frequency. Wafer thickness.	Sampling. "	Frequency counter. Comparator.	"	
	4	Producing section.	"	Size. Frequency. Outer appearance.	Sampling. " "	Comparator. Frequency counter. Micro scope.	"	
	5	Producing section.	"	Outer appearance.	All insprcion.	Micro scope.	"	
	6	Producing section.	"	Frequency.	Sampling.	Network analyzer.	"	
	7	Producing section.	"	Outer appearance.	Sampling.	Micro scope.	"	
	8	Producing section.	"	Airtightness check.	All insprcion.	Leak tester.	"	
	9	Producing section.	"	Outer appearance.	Sampling.	Micro scope.	"	
	10	Producing section.	"	Drive Level Dependency Insulation resistance.	All insprcion. "	Inspectional machine. "	"	
	11	Producing section.	"	Outer appearance.	Sampling.	Micro scope.	"	
	12	Producing section.	"	Crystal impedance. Frequency. Thermistor resistance. Temp. characteristic. Outer appearance.	All insprcion. " " Sampling. All insprcion.	Inspectional machine. " " " Micro scope.	"	
	13	Inspecting section.	Out-going inspection standard	Crystal impedance. Frequency. Insulation resistance.	Sampling. " "	Inspection M/C. " "	Out-going inspection data sheet.	
	14	Producing section.	Manufacturing instruction sheet	Tape-peel strength.	Sampling.	Peelinf force tester.	Process data sheet.	
15	Product control section.	Manufacturing instruction sheet Packing instruction sheet	Address. Quantity.	—	—	Delivery slip.		

Structure Diagram 構造図



Rev.04

Model

型式

FA2016AS

Document No.

管理No.

FA2016AS_D_0001

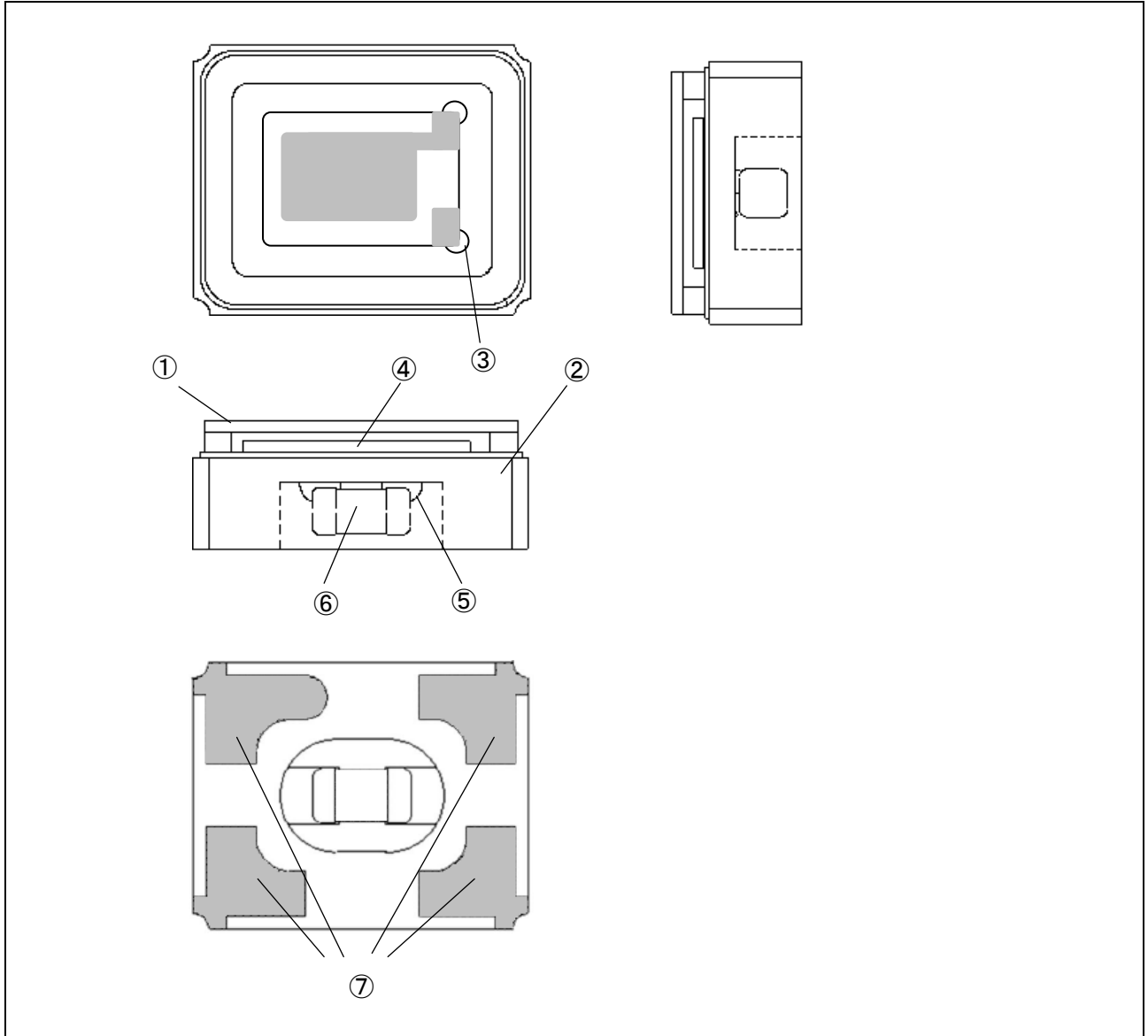

No.	Name of Part 部品名
①	Lid リッド
②	Package パッケージ
③	Crystal Adhesive 水晶接着
④	Crystal chip 水晶片
⑤	Solder はんだ
⑥	Thermistor サーミスタ
⑦	Terminal 端子

RELIABILITY TEST DATA \triangle

Product Name FA2016AS

The Company evaluation condition

We evaluate environmental and mechanical characteristics by the following test condition .

No. DTA-1523

No.	ITEM	TEST CONDITIONS	VALUE *1 *2	TEST	FAIL
			$\Delta f / f$ [1×10^{-6}]	Qty [n]	Qty [n]
1	Shock	150g dummy Jig (SEIKO EPSON Standard) drop from 1500 mm height on the Concrete 3 directions 10 times	※ ± 2	22	0
2	Vibration	10 Hz to 55 Hz amplitude 0.75 mm 55 Hz to 500 Hz acceleration 98 m/s^2 10 Hz \rightarrow 500 Hz \rightarrow 10 Hz 15 min / cycle 6 h (2 h \times 3 directions)	※ ± 2	22	0
3	High temperature storage	+85 °C \times 1 000 h	※ ± 2	22	0
4	Low temperature storage	-40 °C \times 1 000 h	※ ± 2	22	0
5	Temperature cycle	-40 °C \leftrightarrow + 125 °C 30 min at each temp. 100 cycles	※ ± 2	22	0
6	Temperature humidity storage	+85 °C \times 85 %RH \times 1 000 h	※ ± 2	22	0
7	Resistance to soldering heat	For convention reflow soldering furnace (3 times)	± 2	22	0
8	Substrate bending	Bend width reaches 3.0 mm and hold for 5 s \pm 1 s \times 1 time Ref. IEC 60068-2-21	No peeling - off at a solder part	11	0
9	Shear	10 N press for 10 s \pm 1 s Ref. IEC 60068-2-21	No peeling - off at a solder part	11	0
10	Pull - off	10 N press for 10 s \pm 1 s Ref. IEC 60068-2-21	No peeling - off at a solder part	11	0
11	Solderability	Dip termination into solder bath at +235 °C \pm 10 °C for 5 s (Using Rosin Flux)	Termination must be 95 % covered with fresh solder	11	0

Notes

- *1 each test done independently.
- *2 measuring 2 h to 24 h later leaving in room temperature after each test.
- *3 Item No.1 to No.6 shall be tested after following pre conditioning.
- Item No.1 to No.11 resistance at before above tests should be less than $\pm 20 \%$ or less than $\pm 10 \Omega$.
- Pre conditioning : Test crystal must be leaving in room temperature for 24h after reflow \times 3.

Qualification Data

Product Name FA2016AS

$\Delta f / f$

No. DTA-1523

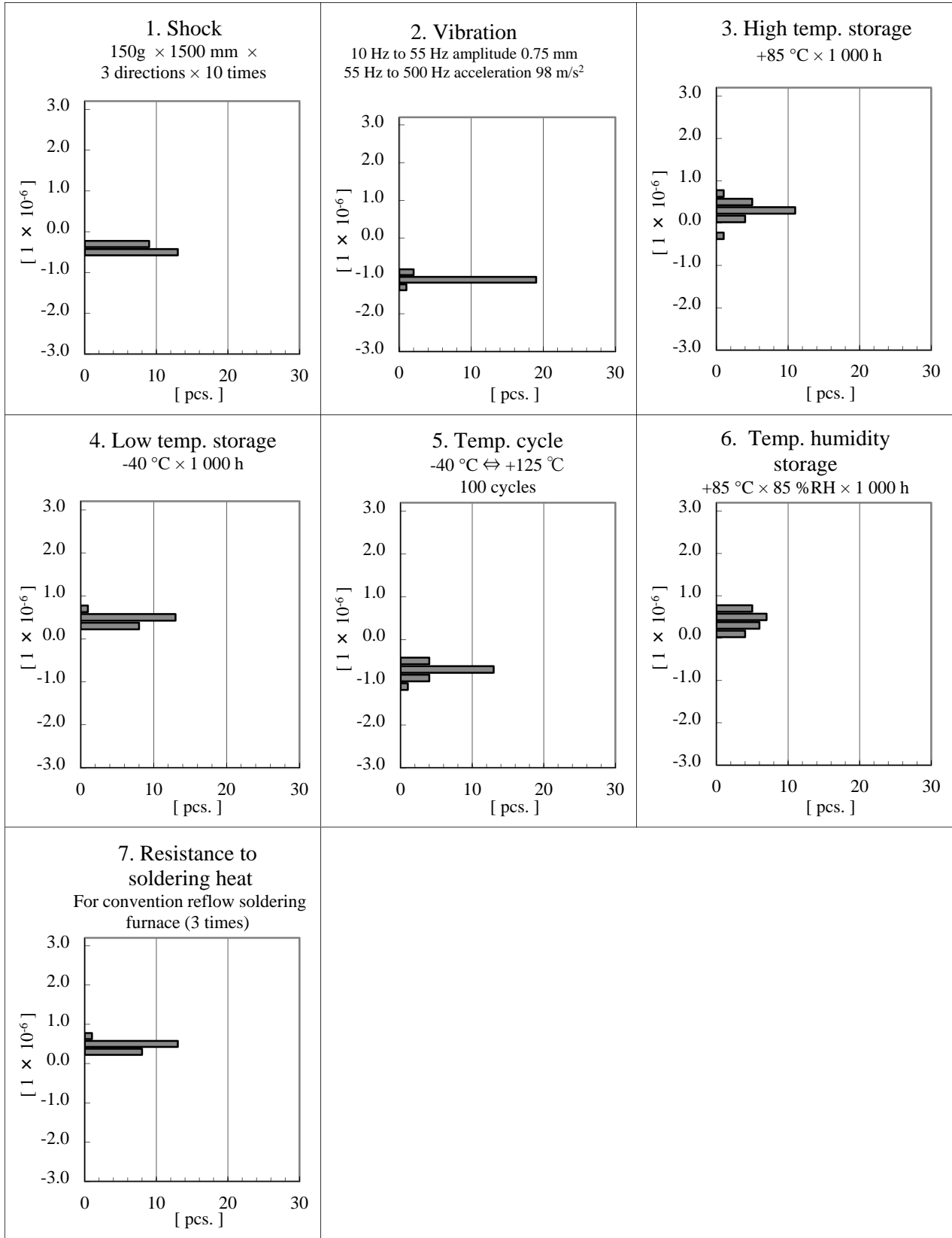

Product Name FA2016AS

Δ CI

No. DTA-1523

