



PRODUCT SPECIFICATION SHEET



Customer	-		
Customer P/N	TBA		
Product Type	Temperature Compensated Crystal Oscillator		
Part Number	9T32000005	Version	S3
Part Description	SMD TCXO 2.0 x 1.6		
Nominal Frequency	32.000000MHz		

Prepared	Li Xiang
Reviewed	Jin Zhe
Approved	Liu Feng
Date	2023/10/20

Customer's Approval & Date :

广东惠伦晶体科技股份有限公司

中国广东省东莞市黄江镇东环路鸡啼岗段68号
 68 Donghuan Road, Jitigang Village, Huangjiang,
 Dongguan, Guangdong Province, P. R. China



WEB : <http://www.dgylec.com/>
 TEL : +86 (0) 769 - 38879888
 FAX : +86 (0) 769 - 38879889
 EMAIL : yl@dgylec.com



Moisture Sensitivity Level 1

CONTENTS

#	Item	Page
1	History of Specification Revision	3
2	Electrical Specifications	4
	2.1 Operation conditions	4
	2.2 Output characteristics	4
	2.3 Frequency characteristics	4
	2.4 Phase noise characteristics	4
3	Product Design	5
	3.1 Package dimensions and pad functions	5
	3.2 Recommended land pattern	5
	3.3 Recommended reflow profile	5
4	Testing Circuit	6

*** Attention**

If you intend to use products on the controlling equipment that relate to medical, aeronautical, aerospace, military science, space and etc, please make sure to let us know your intentions in advance.

Ultrasonic related process may cause damage to crystal blank by resonance itself. If ultrasonic related process is used, we strongly recommend to assess the damage risk under related ultrasonic conditions before use in production.

1. History of Specification Revision

Ver.	Contents	Date	Reviser	Remark
S0	Initial release	2020/12/2	Han Shuang	
S1	Change electrical specifications & Change reflow map	2022/1/29	Li Xiang	
S2	Change electrical specifications	2023/1/31	Li Xiang	
S3	Add attention information	2023/10/20	Li Xiang	

2. Electrical Specifications

2.1 Operation conditions

#	Parameters	Min.	Typ.	Max.	Unit	Remark
1	Nominal frequency	32.000000			MHz	-
2	Supply voltage (V_{DD})	1.68	3.00	3.63	V	-
3	ESD	HBM > 2000V			-	JESD22-A114-B
4	MSL	Level 1			-	IPC/JEDEC J-STD-033C
5	Current consumption	-	-	2.0	mA	-
6	Operating temperature range	-30	-	+85	°C	-
7	Storage temperature range	-40	-	+85	°C	-

2.2 Output characteristics

#	Parameters	Min.	Typ.	Max.	Unit	Remark
1	Output type	Clipped sine wave			-	Decoupling capacitor is required in external circuit
2	Standard output Load	10 K Ω //10 pF			-	-
3	Output level	0.8	-	1.2	V_{pp}	-
4	Duty cycle	40	50	60	%	Ground level
5	Harmonics	-	-	-5	dBc	-
6	Start-up time vs. frequency	-	-	2.0	ms	Within ± 0.5 ppm
7	Start-up time vs. output level	-	-	2.0	ms	$\geq 90\%$ of V_{pp}

2.3 Frequency characteristics

#	Parameters	Min.	Typ.	Max.	Unit	Remark
1	Nominal frequency	32.000000			MHz	-
2	Frequency tolerance after reflow	-2.0	-	+2.0	ppm	At $25 \pm 2^\circ\text{C}$ after 2 times reflow, refer to nominal frequency
3	Frequency stability vs. temperature	-2.5	-	+2.5	ppm	Refer to frequency at 25°C within operating temperature range
4	Frequency stability vs. supply voltage	-0.1	-	+0.1	ppm	$\pm 5\%$ VDD variation
5	Frequency stability vs. load variation	-0.1	-	+0.1	ppm	$\pm 5\%$ load variation
6	Frequency Aging	-1.0	-	+1.0	ppm/ First year	-

2.4 Phase noise characteristics

#	Parameters	Min.	Typ.	Max.	Unit	NOTE
1	Phase noise at 10Hz offset	-	-	-75	dBc/Hz	At $25 \pm 2^\circ\text{C}$
2	Phase noise at 100Hz offset	-	-	-100	dBc/Hz	At $25 \pm 2^\circ\text{C}$
3	Phase noise at 1kHz offset	-	-	-126	dBc/Hz	At $25 \pm 2^\circ\text{C}$
4	Phase noise at 10kHz offset	-	-	-139	dBc/Hz	At $25 \pm 2^\circ\text{C}$
5	Phase noise at 100kHz offset	-	-	-144	dBc/Hz	At $25 \pm 2^\circ\text{C}$

3. Product Design

3.1 Package dimensions and pad functions

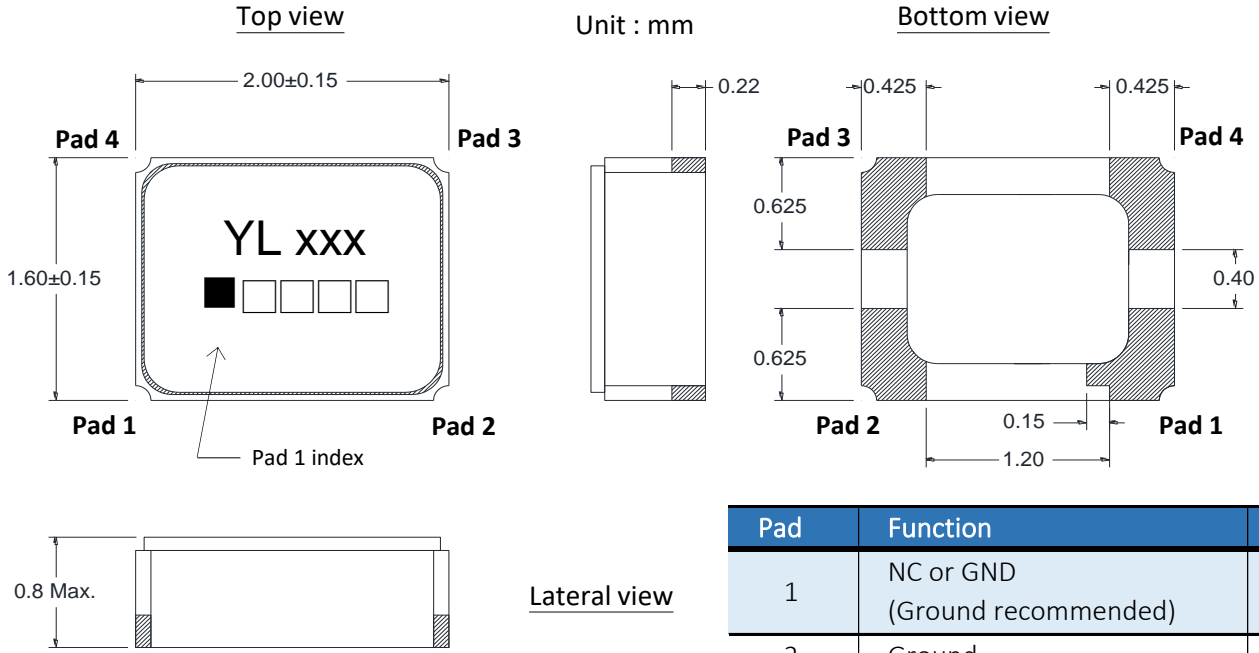

Pad	Function	Symbol
1	NC or GND (Ground recommended)	NC
2	Ground	GND
3	Output	OUT
4	Supply voltage	V _{DD}

3.2 Recommended land pattern

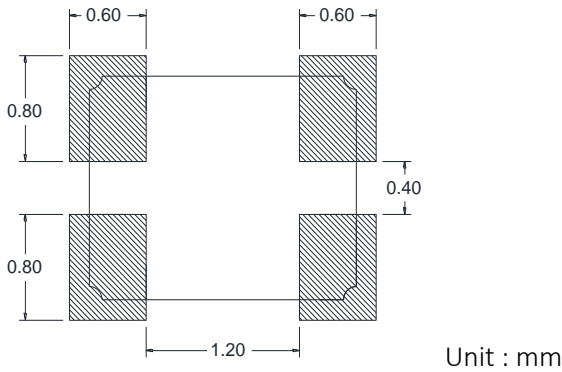

3.3 Recommended reflow profile

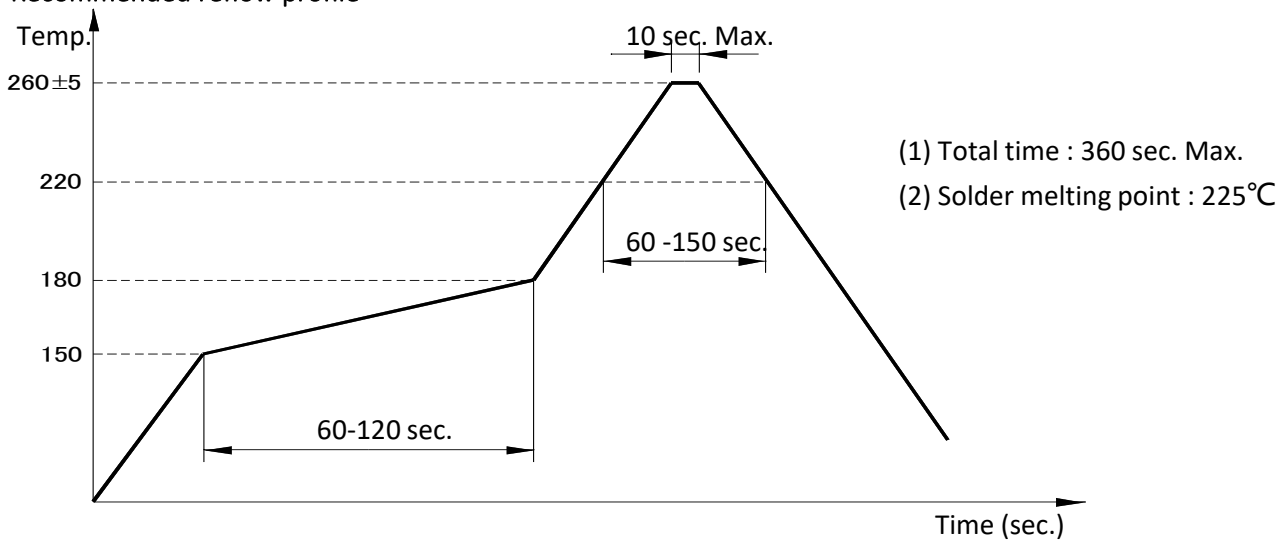

4. Testing Circuit

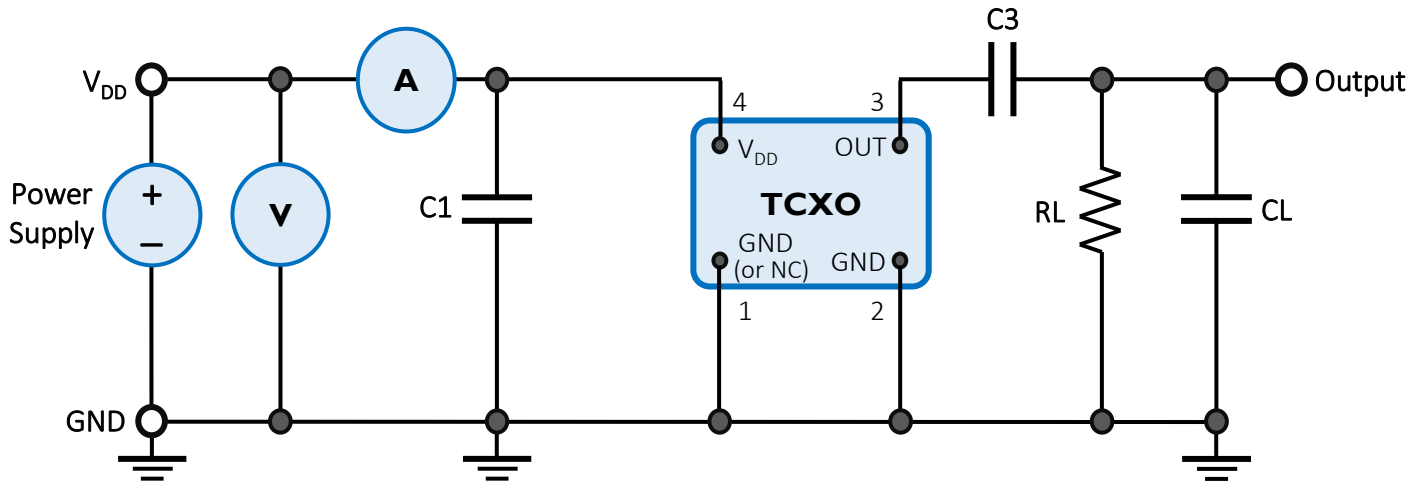

External Components:

Parts	Function	Recommended
C1	AC noise bypass for V_{DD}	10nF
C3	DC block for output	10nF
RL	Load resistance	10K Ω
CL	Load capacitance	10pF