



## PRODUCT SPECIFICATION SHEET



<b>Customer</b>	-		
<b>Customer P/N</b>	-		
<b>Product Type</b>	Temperature Sensing Crystal		
<b>Part Number</b>	9K26000001	<b>Version</b>	S0
<b>Part Description</b>	SMD TSX 2.0 x 1.6 (TH + Xtal)		
<b>Nominal Frequency</b>	26.000000 MHz		

<b>Prepared</b>	Li Xiang
<b>Reviewed</b>	Kuro Peng
<b>Approved</b>	Liu Feng
<b>Date</b>	2023/10/27

**Customer's Approval & Date :**

### 广东惠伦晶体科技股份有限公司

中国广东省东莞市黄江镇东环路鸡啼岗段68号  
68 Donghuan Road, Jitigang Village, Huangjiang,  
Dongguan, Guangdong Province, P. R. China



WEB : <http://www.dgylec.com/>

TEL : +86 ( 0 ) 769 - 38879888

FAX : +86 ( 0 ) 769 - 38879889

EMAIL : yl@dgylec.com



**AEC-Q200 Qualified**

## CONTENTS

#	Item	Page
<b>1</b>	<b>History of Specification Revision</b>	<b>3</b>
<b>2</b>	<b>Electrical Specifications</b>	<b>4</b>
	2.1 Specifications for operation condition and electrical characteristics	4
	2.2 Specifications for crystal drive level dependency (DLD)	5
	2.3 Specifications for GPS quality	6
	2.4 NTC thermistor specification table	7
<b>3</b>	<b>Product Design</b>	<b>8</b>
	3.1 Package dimensions and pad functions	8
	3.2 Recommended land pattern	8
	3.3 Recommended reflow profile	8
	3.4 Marking definition	9
	3.5 Recommended reflow profile	9
	3.6 Structure illustration	10
<b>4</b>	<b>Reliability Assurance</b>	<b>11</b>
	4.1 Mechanical endurance	11
	4.2 Environmental endurance	11
<b>5</b>	<b>Taping and Packing</b>	<b>12</b>
	5.1 Tape and reel	12
	5.2 Packing standard	13
<b>6</b>	<b>Specification of the Environment-related Substances</b>	<b>14</b>

### \* Attention

If you intend to use products on the controlling equipment that relate to medical, aeronautical, aerospace, military science, space and etc, please make sure to let us know your intentions in advance.

Ultrasonic related process may cause damage to crystal blank by resonance itself. If ultrasonic related process is used, we strongly recommend to assess the damage risk under related ultrasonic conditions before use in production.



## 2. Electrical Specifications

### 2.1 Specifications for operation condition and electrical characteristics

#	Parameter	Min.	Typ.	Max.	Unit	Remark
1	Nominal frequency	26.000000			MHz	-
2	Crystal cut type	AT-cut			-	-
3	Mode of vibration	Fundamental			-	-
4	Load capacitance (C <sub>L</sub> )	-	8.0	-	pF	Note 1.
5	ESD	HBM > 2000V			-	JESD22-A114-B
6	MSL	Level 1			-	IPC/JEDEC J-STD-033C
7	Drive level	0.01	50	100	μW	-
8	Operating temperature range	-40	-	+105	°C	-
9	Storage temperature range	-40	-	+105	°C	-
10	Initial frequency tolerance	-10	-	+10	ppm	At 25±3°C, drive level 10μW
11	Frequency drift after reflow	-2.0	-	+2.0	ppm	After two times of reflow
12	Frequency tolerance over temperature	-12	-	+10	ppm	Within -30°C to +85°C. Above +85°C see.
		-30	-	+30	ppm	Within -40°C to +105°C. Above +85°C see.
13	Frequency aging	-0.7	-	+0.7	ppm/First year	At 25±2°C
		-1.4	-	+1.4	ppm/2 years	
		-2.5	-	+2.5	ppm/5 years	
		-5	-	+5	ppm/10 years	
14	Tuning sensitivity	10.8	12.0	13.2	ppm/pF	-
15	Equivalent series resistance (ESR)	-	-	50	Ω	Note 2.
16	Insulation resistance	500	-	-	MΩ	-
17	Quality factor (Q)	75,000	-	-	-	-
18	Inflection point	29.0	30.5	32.0	°C	Specified at max drive level. $t = \left( t_0 - \frac{C2}{3C3} \right)$
19	First-order curve fitting parameter (C1)	-0.40	-0.25	-0.10	ppm/°C	-
20	Second-order curve fitting parameter (C2)	-4.5	0	+4.5	x10 <sup>-4</sup> ppm/°C <sup>2</sup>	-
21	Third-order curve fitting parameter (C3)	+8.7	+9.85	+11	x10 <sup>-5</sup> ppm/°C <sup>3</sup>	-

Note 1 The load capacitance is measured according to IEC Standard #60444-8.

Note 2 The ESR max is specified at max drive level minimum Q, drives a smaller ESR; that is, design the crystal to the minimum Q.

2. Electrical Specifications (Cont.)

2.2 Specifications for crystal drive level dependency (DLD)

#	Parameter	Min.	Typ.	Max.	Unit	Remark
1	Drive level measurement condition	0.01	-	100	μW	Drive level from 0.01 μW to 100 μW to 0.01 μW
2	DLD Frequency (maximum - minimum)	-	-	3.5	ppm	Define as FDL. Note 3.
3	DLD Frequency (repeatability)	-	-	0.7	ppm	Define as FDLH. Note 4.
5	DLD ESR (maximum - minimum)	-	-	2.5	Ω	Define as DLD2. Note 3.
6	DLD ESR (repeatability)	-	-	1.5	Ω	Define as DLDH2. Note 4.

Note 3 Maximum - minimum: Difference between the maximum and minimum in a two-way measurement.

Note 4 Repeatability of the two-way measurement is defined in the above Drive level measurement condition.

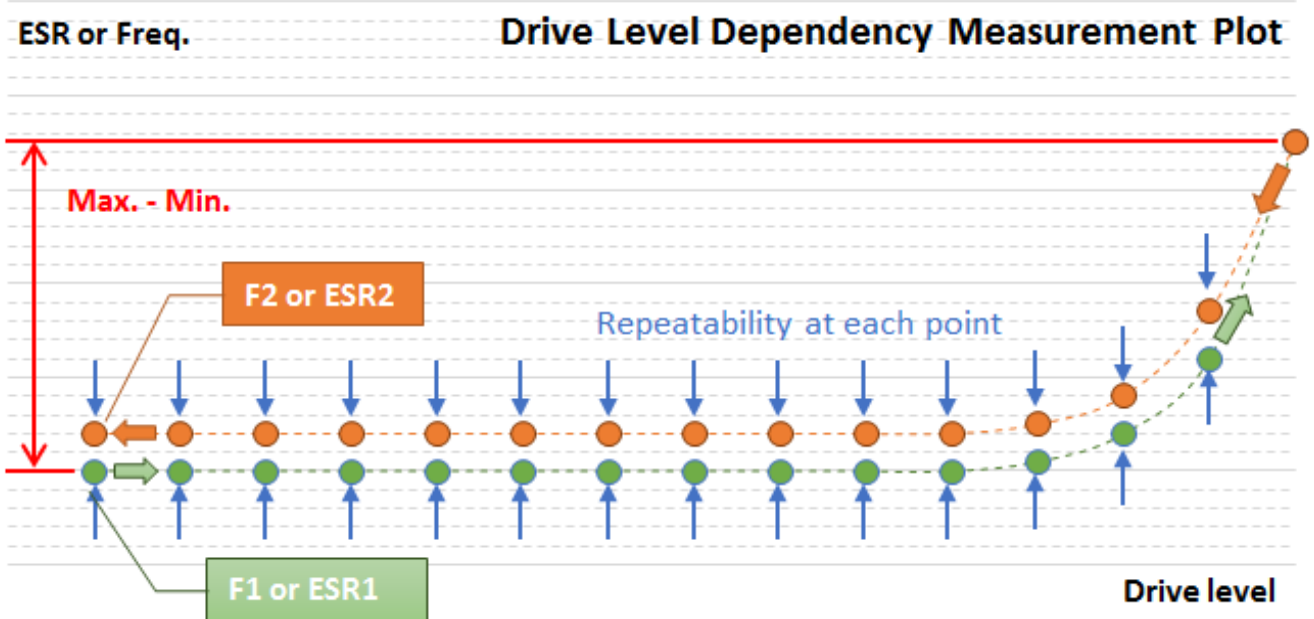

## 2. Electrical Specifications (Cont.)

### 2.3 Specifications for GPS quality

#	Parameter	Min.	Typ.	Max.	Unit	Remark
1	Drive level measurement condition	100			μW	All measurements in GPS quality are taken at 100 μW drive level.
2	Full Cycle frequency stability slope	-50	-	+50	ppb/°C	Note 5.
3	5°C Small cycle frequency stability slope	-50	-	+50	ppb/°C	Note 6.
4	Full cycle temperature hysteresis	-0.5	-	+0.5	ppm	Note 7.
5	5°C Small cycle temperature Hysteresis	-0.05	-	+0.05	ppm	Note 8.

Note 5 Test condition: Continuous temperature rate change of ~ 1.0°C/min  
 Measure FT points every 1°C, heating up from -30 to 85°C, subtract a fifth-order polynomial best fit, and then calculate the slope of the residual.

Note 6 Test condition: Continuous temperature rate change of ~ 1.0°C/min  
 Measure FT points every 0.5°C, heating up from -30 to 85°C, subtract a fifth-order polynomial best fit, and then calculate the slope of the residual.

Note 7 Temp. range: -30 to 85°C for each 1°C, Temp. rate: ~1.0°C/min  
 Test flow: 25°C(1) → -30°C → 85°C → 25°C(2), (25°C(1) freq. drift subtract 25°C(2) freq. drift)

Note 8 Temp. range: -30 to 85°C for each 0.5°C, Temp. rate: ~1.0°C/min, Test flow: any 5°C cycle  
 (ex. 25°C(1) → -30°C → 25°C(2), 25°C(1) freq. drift subtract 25°C(2) freq. drift)

## 2. Electrical Specifications (Cont.)

### 2.4 NTC thermistor specification table

#	Parameter	Min.	Typ.	Max.	Unit	Remark
1	Operating temperature range	-40	-	+105	°C	-
2	Storage temperature range	-40	-	+105	°C	-
3	Resistance	-	100	-	kΩ	At 25°C*
4	B-constant	-	4,250	-	K	At 25°C - 50°C
5	Tolerance	-	-	1	%	-

\*In order to get the precise resistance value of the thermistor, the temperature control will be very important during testing since the resistance value will change ~4% per 1°C temperature difference.

Please check the following Murata website for detail explanation.

<https://www.murata.com/en-us/support/faqs/products/thermistor/ntc/pct/0001>

### 3. Product Design

#### 3.1 Package dimensions and pad functions (Unit : mm)

#### 3.2 Pad connection diagram and function

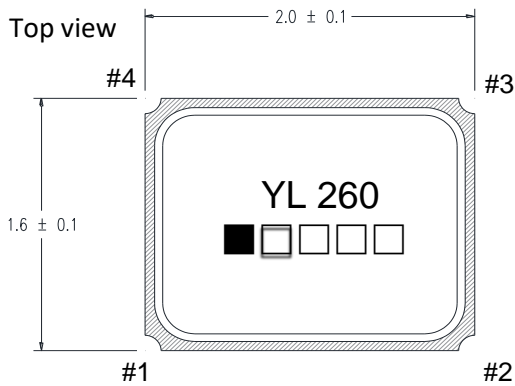

Lateral view

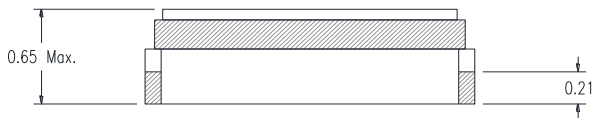

Bottom view

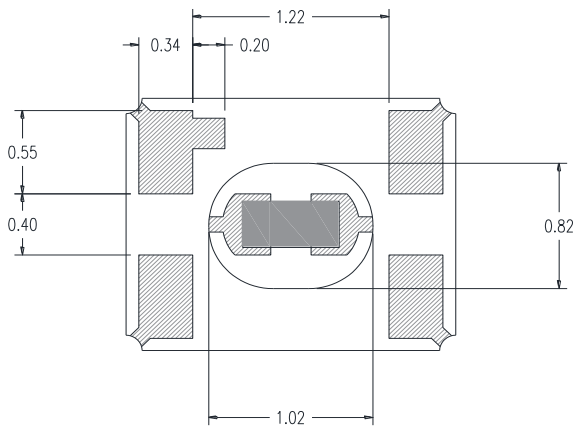

Bottom view

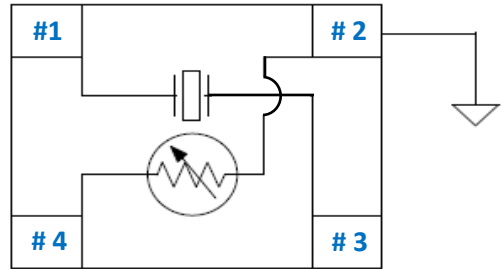

Pad	Function
1	Xtal in
2	Thermistor out, connecting to ground
3	Xtal out
4	Thermistor in

#### 3.3 Recommended land pattern (Unit : mm)

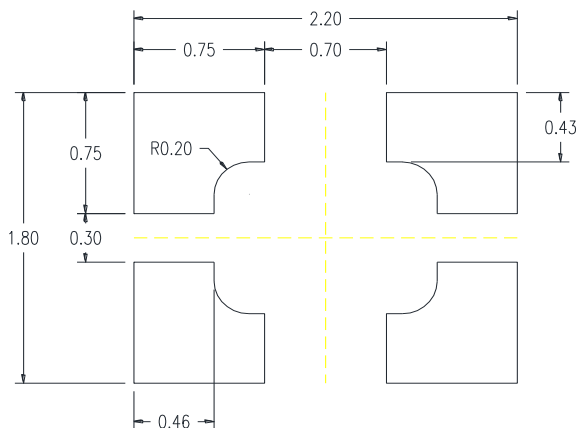



### 3. Product Design (Cont.)

#### 3.4 Marking definition

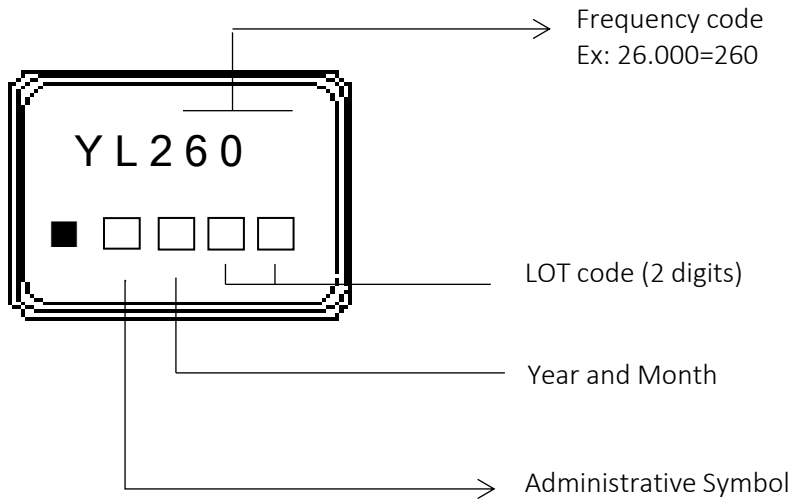
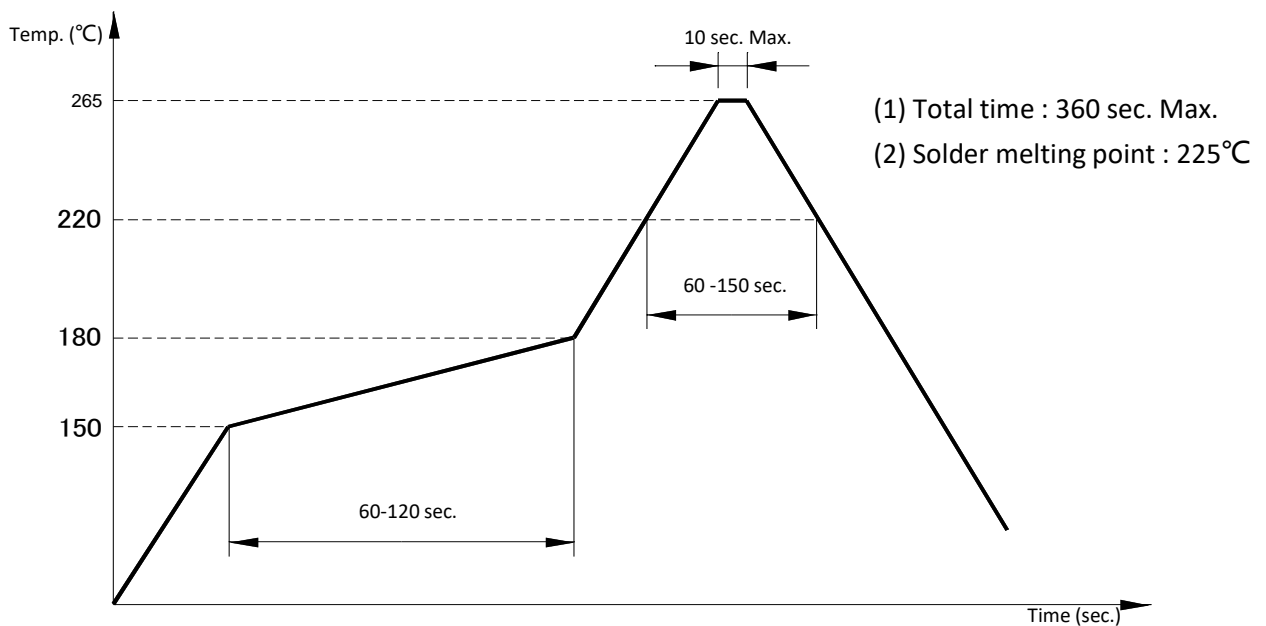

Table of Year and Month code

		Month											
Year		JAN	FEB	MAR	APR	MAY	JUN	JUL	AUG	SEP	OCT	NOV	DEC
2017	2021	A	B	C	D	E	F	G	H	J	K	L	M
2018	2022	N	P	Q	R	S	T	U	V	W	X	Y	Z
2019	2023	a	b	c	d	e	f	g	h	j	k	l	m
2020	2024	n	p	q	r	s	t	u	v	w	x	y	z

#### 3.5 Recommended reflow profile



### 3. Product Design (Cont.)

#### 3.6 Structure illustration

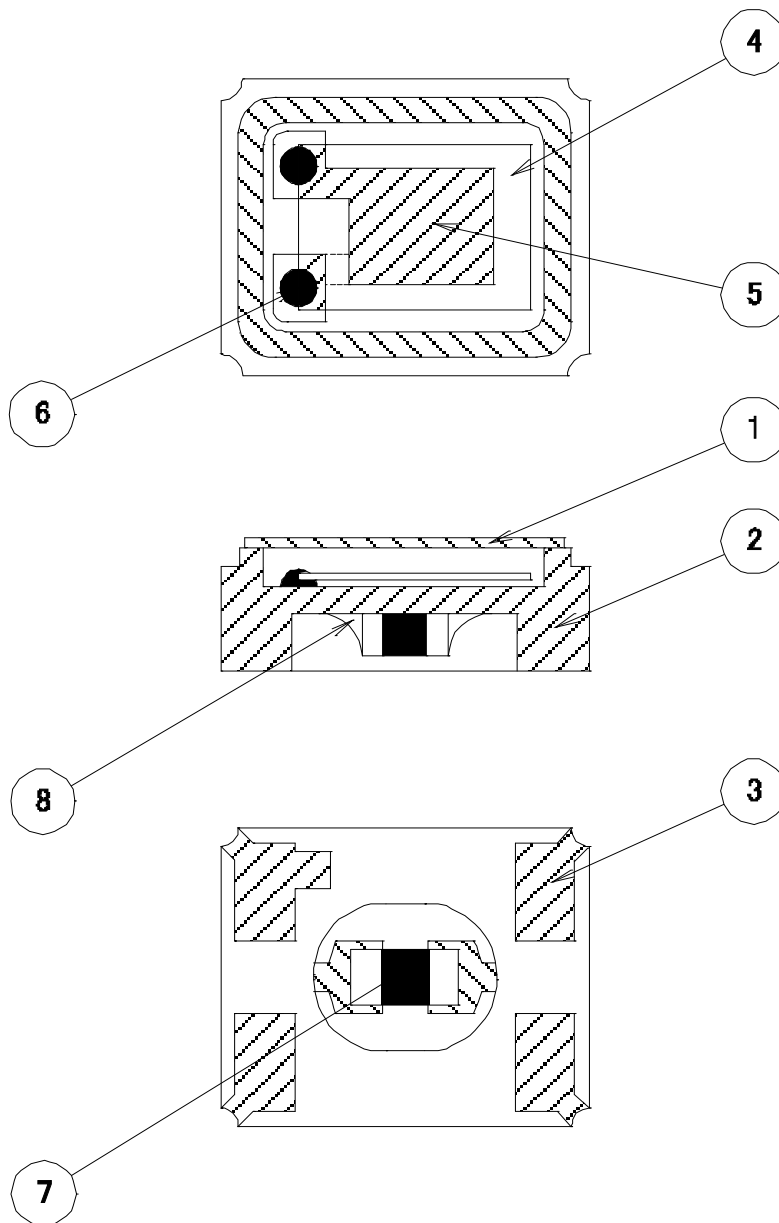

#	Components	Materials	QTY	Finish/Specifications
1	Cap (Lid)	Kovar (Fe + Co + Ni)	1	Ni plating
2	Base (Package)	Ceramic (Al <sub>2</sub> O <sub>3</sub> ) + Kovar (Fe + Co + Ni)	1	Alumina ceramics
3	Pad (Package)	Ni + Au	4	Tungsten metalization + Ni plating + Au plating
4	Crystal blank	SiO <sub>2</sub>	1	-
5	Electrode	Cr + Nobel material	2	
6	Conductive adhesive	Ag	2	Silicone resin
7	Thermistor	Alumina Ceramics (Al <sub>2</sub> O <sub>3</sub> ), Ni + Ag+ Sn	1	-
8	Solder	Sn + Ag + Cu	2	-

## 4. Reliability Assurance

### 4.1 Mechanical endurance

#	Item	Test Condition	Reference
1	Drop test	150 cm height, fall freely onto stainless plate, 3 times.	JIS C6701
2	Shock test	150 g weight, 150 cm height onto concrete floor. Each direction ( $\pm x, \pm y, \pm z$ ) for 3 cycles.	IEC-68-02-27
3	Mechanical shock	Half sine wave 1000 G. Three mutually perpendicular axes, each axis for 3 times. Duration time 1.0ms.	MIL-STD-202F
4	Vibration	10 to 55 Hz 0.75mm, 55 to 2000Hz 20G, 4 hours to each three axis (x, y, z). Total test time 6 hours.	MIL-STD-883E
5	Gross Leak	Standard sample for automatic gross leak detector. Test pressure: 2kg/cm <sup>2</sup> .	MIL-STD-883E
6	Fine Leak	Helium bombing 4.5 kgf/cm <sup>2</sup> for 2 hours.	MIL-STD-883E
7	Solderability	Temperature : 260°C $\pm$ 5°C Immersing depth : 0.5 mm minimum Immersion time : 5 $\pm$ 1 seconds Flux : Rosin resin methyl alcohol solvent (1:4)	GB/T 2424.17-2008 / IEC 60068-2-44:1995; GB/T 2423.28-2005 / IEC 60068-2-20:1979

### 4.2 Environmental endurance

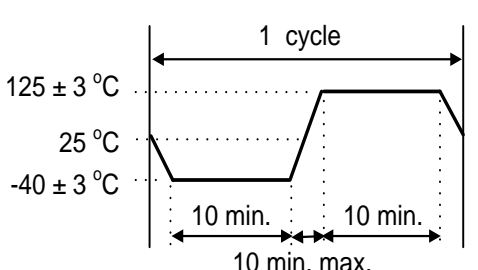
#	Item	Test Condition	Reference
1	High temperature storage	Temperature : +125°C $\pm$ 3°C Duration : 500 $\pm$ 12 hours	MIL-STD-883E
2	Low temperature storage	Temperature : -40°C $\pm$ 3°C Duration : 500 $\pm$ 12 hours	MIL-STD-883E
3	Thermal shock (Air to Air)	Total 100 cycles of the following temperature cycle 	MIL-STD-883E
4	High temperature & humidity	Temperature : 85°C $\pm$ 3°C Humidity : RH 85% Duration : 500 hours	JIS C5023

5. Taping and Packing

5.1 Tape and reel (EIA-481-2)

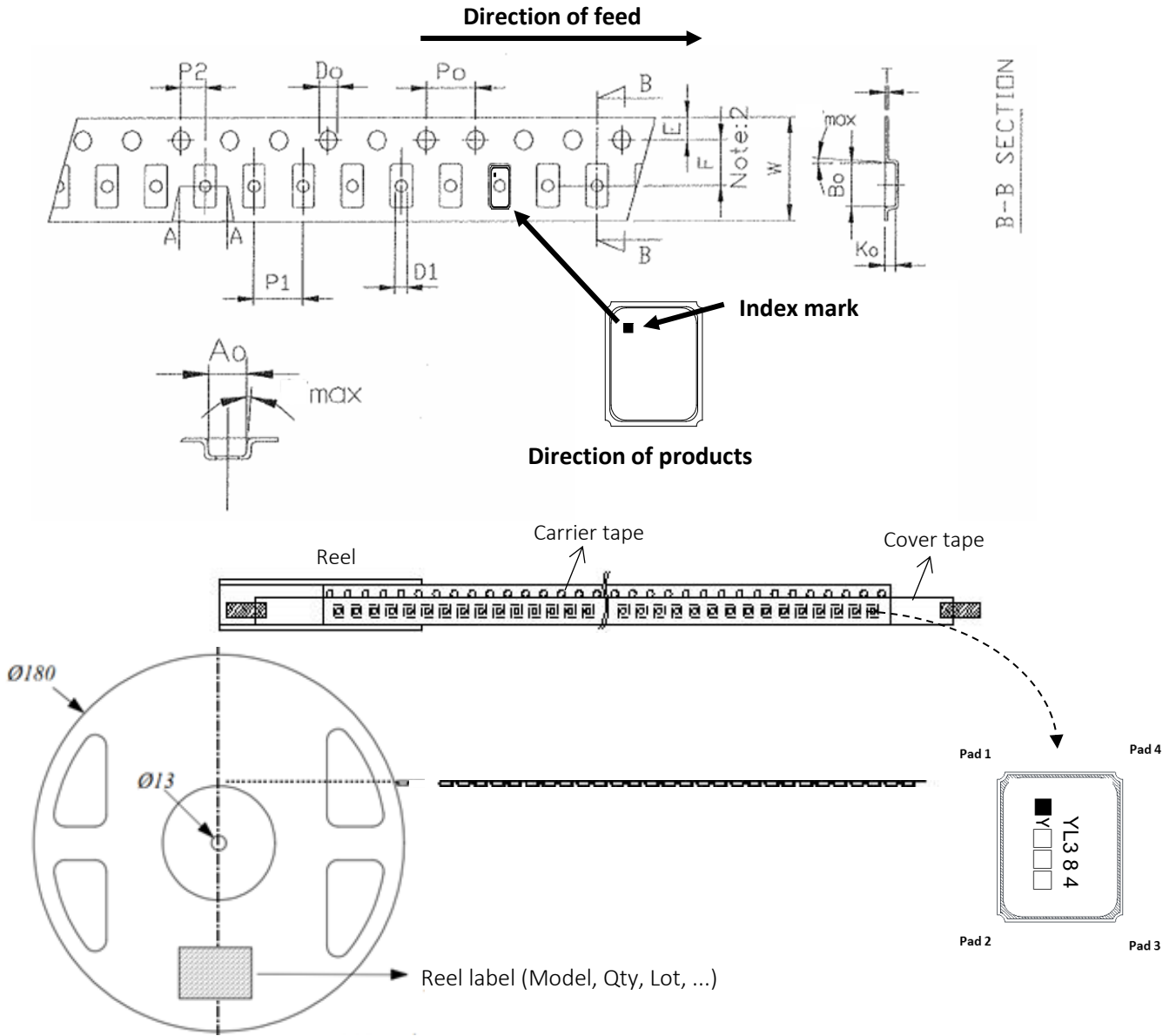

Package Type	Dimension (Unit : mm)						
2016 TSX (8mm)	A <sub>0</sub>	B <sub>0</sub>	K <sub>0</sub>	T	W	E	F
	1.90±0.1	2.30±0.1	1.25±0.1	0.25±0.05	8.00±0.3	1.75±0.2	3.50±0.1
	P1	P2	D1	D <sub>0</sub>	P <sub>0</sub>		
	4.00±0.1	2.00±0.1	1.00±0.1	1.55±0.05	4.00±0.1		

Standard Reel Quantity is 3000 pcs per reel.

The inspection standard of tape tension

Item		Defect	Method
Appearance	All	1. The tape is not coincidence 2. The bubble	Visual inspection
Tape tension	2016 - 8mm	Overstep 34±6g (28 to 40g)	Pull test



## 5. Taping and Packing (Cont.)

### 5.2 Packing standard

Out-going packing instruction

Reel packing	Inner packing	Carton
Name : Reel Standard : Diameter 18cm Material : Plastics Name : Anti-static shielding bag Standard : 205×250mm Material : APET/CPP	Name : Bubble wrap Standard : 430×330×(t)20mm Material : HDPE Quantity : Max.15 reels	Name : Carton Standard : 400×400×(H)280mm Material : AB corrugated paper Quantity : 4 bags
 <p>L1</p>		 <p>L2</p>

The label information

Label	Label Drawing	Name of Article	Spec.	Label size	Printing
L1		条码标签 Bar Code Label (Chintz Paper)	1. Part No. 2. Lot No. 3. Q'ty 4. Freq.	70×50mm	White
L2		条码标签 Bar Code Label (Chintz Paper)	1. Part No. 2. Date Code 3. Q'ty 4. Freq.	70×50mm	White

Remark: Specifications on the label is for default templates purpose and may change with different product.  
 If any specified requirements for labels packaging is needed, please provide the instruction information.

## 6. Specification of the Environment-related Substances

#	Range	Max. concentration (ppm; mg/kg)	
	Banned Substances	Product	Packing
1	镉及镉化合物 Cadmium and cadmium compounds	100	100
2	铅及铅化合物 Lead and lead compounds	1000	100
3	汞及汞化合物 Mercury and mercury compounds	1000	100
4	六价铬化合物 Hexavalent-Chromium VI (Cr <sup>+6</sup> )	1000	100
5	聚溴联苯 PBB Polybrominated biphenyls	1000	N/A
6	聚溴二苯醚 PBDE Polybrominated diphenyl ethers	1000	N/A
7	邻苯二甲酸二(2-乙基己基)酯 DEHP Di (2-ethylhexyl) phthalate	1000	N/A
8	邻苯二甲酸丁苄酯 BBP Butyl Benzyl Phthalate	1000	N/A
9	邻苯二甲酸二丁酯 DBP Dibutyl Phthalate	1000	N/A
10	邻苯二甲酸二异丁酯 DIBP Diisobutyl Phthalate	1000	N/A
11	氟(F)、氯(Cl)、溴(Br)、碘(I) Fluorine, Chlorine, Bromine, Iodine	900、900、900、900 注：Br + Cl < 1000	N/A
12	包装材料中重金属(汞、镉、六价铬、铅、PBB、PBDE)之总量 Heavy metals (mercury, cadmium, lead, Cr <sup>+6</sup> , PBB and PBDE) in packing materials	N/A	100 铅(Pb) + 镉(Cd) + 汞(Hg) + 六价铬(Cr+6) < 100ppm
13	高度关注物质 SVHC-Substances of Very High Concern	1000	N/A