



PRODUCT SPECIFICATION SHEET

CUSTOMER : _____

PRODUCT TYPE : SMD TSX 2.5×2.0

NOMINAL FREQ. : 26.000000 MHz

FL P/N : 2Z26000007

REVISION : A4

CUSTOMER P/N : _____

CUSTOMER'S APPROVAL & DATE

--

FL CORPORATION

APPROVED	CHECKED	DESIGNED
Jay Lee	Kuro Peng	Chen XuanRu

MSL 1

RoHS Compliant



CONTENTS

PAGE

- SPECIFICATION REVISION RECORD SHEET 2
- ELECTRICAL SPECIFICATIONS 3 to 4
- CONNECTION DIAGRAM, DIMENSIONS & MARKING 5
- MARKING 6
- SUGGESTED REFLOW PROFILE 6
- STRUCTURE ILLUSTRATION 7
- RELIABILITY TEST SPECIFICATIONS 8
- PACKING 9 to 10
- SPECIFICATION OF THE ENVIRONMENT-RELATED SUBSTANCES 11

ATTACHMENT (optional)

- ELECTRICAL CHARACTERISTICS TEST A YES NO
- TEMPERATURE CHARACTERISTICS TEST B YES NO



PRODUCT DESCRIPTION

Standard atmospheric conditions

Unless otherwise specified, the standard range of atmospheric conditions for making measurement and tests are as follow:

Ambient temperature : 25±10°C

Relative humidity : 40% to 70%

If there is no doubt the results, measurement shall be made within the following limits:

Ambient temperature : 25±3°C

Relative humidity : 40% to 70%

Measure equipment

Electrical characteristics are measured by S&A250B or equivalent.

Crystal cutting type

The crystal is using AT CUT (thickness shear mode).

ELECTRICAL SPECIFICATIONS

#	Parameters	Symbol	Electrical Spec.			Units	Notes
1	Nominal frequency	FL	26.000000			MHz	
2	Oscillation mode	-	AT-cut Fundamental			NA	
3	Load capacitance	CL	-	7	-	pF	
4	Frequency tolerance	dF	-10	-	+10	ppm	At 25±2°C
5	Frequency Temperature Characteristics	dFr	-12	-	+10	ppm	At -30 ~ +85°C (reference 25°C)
6	Frequency drift after reflow	-	-2	-	+2	ppm	After two reflows (0.5Hr freq. drift substruct 168Hr freq. drift)
7	Aging (/1 year)	Fa	-0.7	-	+0.7	ppm/year	at 25±2°C
8	Aging (/2 year)		-1.4	-	+1.4	ppm/2year	
9	Aging (/5 year)		-2.5	-	+2.5	ppm/5year	
10	Aging (/10 year)		-5	-	+5	ppm/10year	
11	Operating temperature	-	-30	-	+105	°C	
12	Storage temperature	-	-40	-	+105	°C	
13	Equivalent series resistance	ESR	-	-	50	Ω	
14	Quality factor	Q	75,000	-	-	NA	
15	Spurious mode series resistance	-	500	-	-	Ω	±500KHz
16	Pullability	S	13.5	15	16.5	ppm/pF	
17	Inflection point	Ti	29	30.5	32	°C	
18	Room temperature	T0	-	30.5	-	°C	
19	Insulation resistance	IR	500	-	-	MΩ	At DC 100V
20	Drive level	DL	10	50	100	μW	
21	First-order curve fitting parameter	C1	-0.4	-0.25	-0.1	ppm/°C	Ta=-40 to +85°C per 1°C (Note 1)
22	Second-order curve fitting parameter	C2	-4.5	0	+4.5	×10 ⁻⁴ ppm/°C ²	
23	Third-order curve fitting parameter	C3	8.7	9.85	11	×10 ⁻⁵ ppm/°C ³	



ELECTRICAL SPECIFICATIONS (CONT.)

#	Parameters	Symbol	Electrical Spec.			Units	Notes
24	Full Cycle Temperature Hysteresis	-	-0.5	-	+0.5	ppm	'at -30~+85°C (Note 2)
25	5°C Small Cycle Temperature Hysteresis	-	-0.05	-	+0.05	ppm	(Note 3)
26	Full Cycle Frequency stability slope	-	-50	-	+50	ppb/°C	(Note 4)
27	5°C Small Cycle Frequency stability slope 1	-	-50	-	+50	ppb/°C	(Note 4)
28	DLD Freq. (Max-Min)	FDDL	-	-	3.5	ppm	Drive Level 10nW~100uW Step Ratio is sqrt10
29	DLD Freq. (Hysteresis)	FDLDH	-	-	0.7	ppm	
30	DLD ESR (Max-Min)	DLD2	-	-	2.5	Ω	
31	DLD ESR (Hysteresis)	DLDH2	-	-	1.5	Ω	

Note 1 Measure FT points every 1°C, heating up from -40 to 85°C, substrat a third-order polynomial best fit.
 $F(T) = C3(T-To)^3 + C2(T-To)^2 + C1(T-To)$; $To = 30.5°C$

Note 2 Temp. range:-30 to 85°C for each 1°C, Temp. rate: ~1.0°C/min
 Test flow: 25°C(1)->-30°C->85°C->25°C(2), (25°C(1) freq. drift subtract 25°C(2) freq. drift)

Note 3 Temp. range:-30 to 85°C for each 0.5°C, Temp. rate: ~1.0°C/min, Test flow: any 5°C cycle (ex.25°C(1)->-30°C->25°C(2), 25°C(1) freq. drift subtract 25°C(2) freq. drift)

Note 4 Test condition: Continuous temperature rate change of~ 1.0°C/min
 Measure FT points every 1°C, heating up from -30 to 85°C, subtract a fifth-order polynomial best fit, and then calculate the slope of the residual.

NTC THERMISTOR SPECIFICATIONS TABLE

#	Parameters	Symbol	Electrical Spec.			Units	Notes
1	Operating Temperature	-	-30		+105	°C	
2	Storage Temperature	-	-40		+105	°C	
3	Resistance	-		100		kΩ	At 25°C
4	B-constant	-		4250		K	At 25°C - 50°C
5	Tolerance	-	-1		+1	%	



CONNECTION DIAGRAM

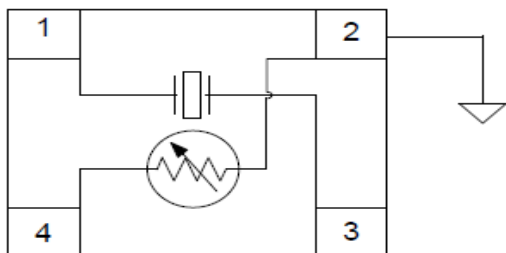

DIMENSIONS (Unit : mm)

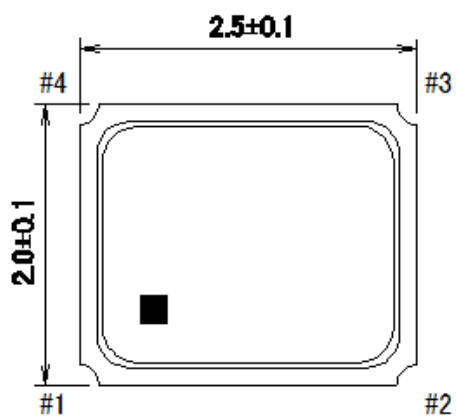

Pad	Function
#1	Xtal terminal (Input)
#2	Thermistor + GND terminal
#3	Xtal terminal (Output)
#4	Thermistor terminal

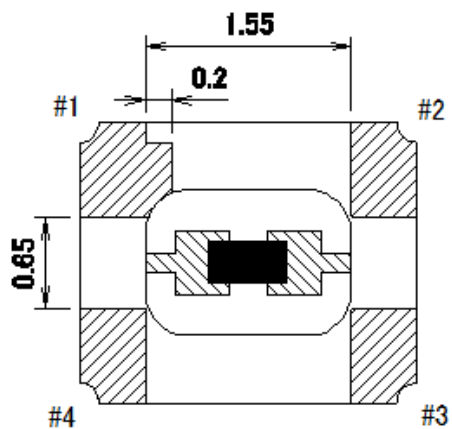

SUGGESTED LAYOUT

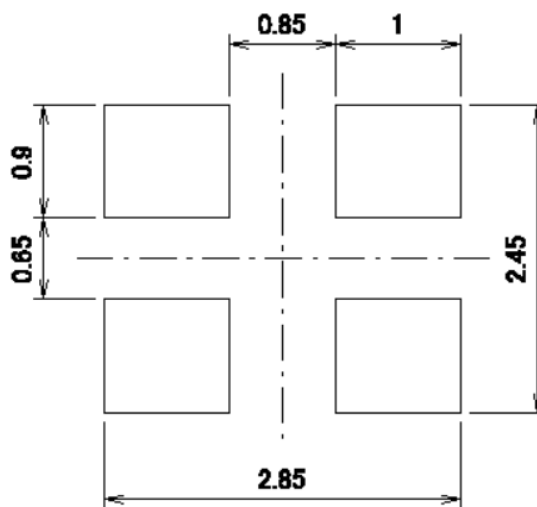



MARKING

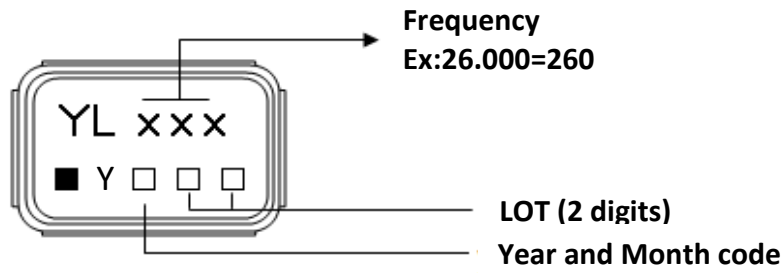

		month											
year		JAN	FEB	MAR	APR	MAY	JUN	JUL	AUG	SEP	OCT	NOV	DEC
2017	2021	A	B	C	D	E	F	G	H	J	K	L	M
2018	2022	N	P	Q	R	S	T	U	V	W	X	Y	Z
2019	2023	a	b	c	d	e	f	g	h	j	k	l	m
2020	2024	n	p	q	r	s	t	u	v	w	x	y	z

SUGGESTED REFLOW PROFILE

Total time : 360 sec. Max.

Solder melting point :225 °C

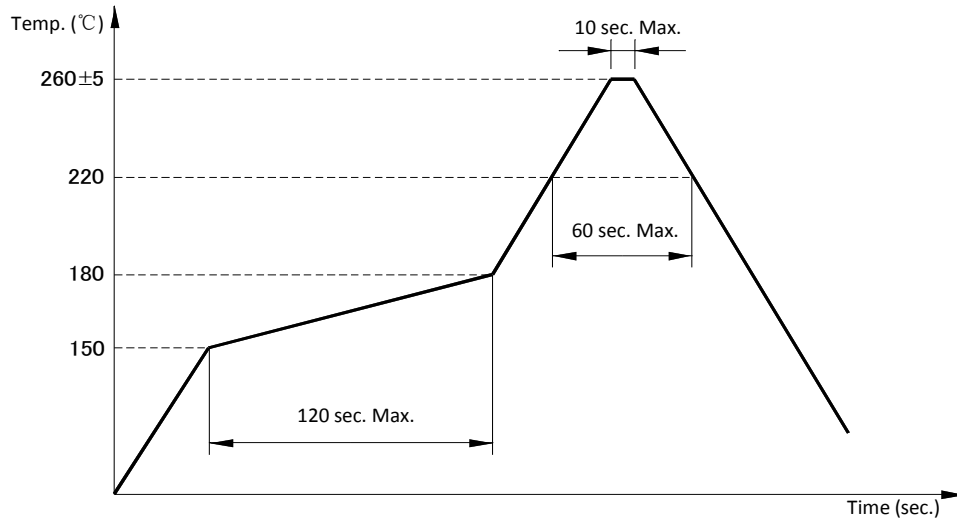



STRUCTURE ILLUSTRATION

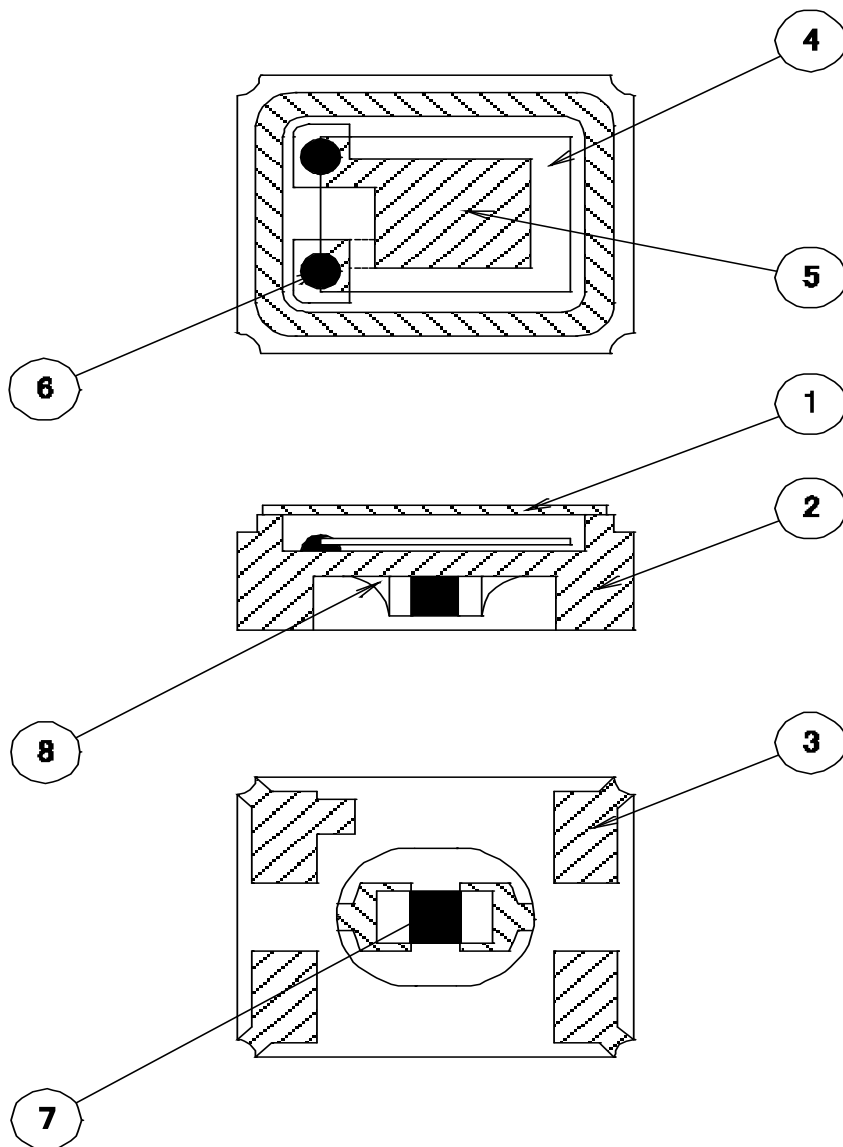

#	COMPONENTS	MATERIALS	QTY	FINISH/SPECIFICATIONS
1	Cap (Lid)	Kovar (Fe+Co+Ni)	1	Ni plating
2	Base (Package)	Alumina Ceramics (Al ₂ O ₃) + Kovar (Fe+Co+Ni)	1	
3	Pad (Package)	Ni + Au	4	
4	Crystal Blank	SiO ₂	1	
5	Electrode	Cr + Nobel material	2	
6	Conductive Adhesive	Ag	2	Silicone resin
7	Thermistor	Alumina Ceramics (Al ₂ O ₃), Ni + Ag+ Sn	1	
8	Solder	Sn + Ag + Cu	2	



RELIABILITY SPECIFICATIONS

1. MECHANICAL ENDURANCE

No.	Test Item	Test Methods	
1	Drop test	150 cm height, fall freely onto stainless plate 3 times.	JIS C6701
2	Shock test	150g/150cm height, 3times in the direction of $\pm x$, $\pm y$, $\pm z$ on concrete floor.	IEC-68-02-27
3	Mechanical shock	Device are shocked to half sine wave (1000 G) three mutually perpendicular axes each 3 times. 1.0ms duration time.	MIL-STD-202F
4	Vibration	Frequency range 10 to 55 Hz Amplitude 1.52 mm Perpendicular axes each test time 2 hours (x, y, z axis) Total test time 6 hours	MIL-STD-883E
5	Gross leak	Standard sample for automatic gross leak detector. Test pressure 2kg/cm ² .	MIL-STD-883E
6	Fine leak	Helium bombing 4.5kgf/cm ² for 2 hours.	MIL-STD-883E
7	Solderability	Temperature 215°C \pm 5°C Immersing depth 0.5 mm minimum Immersion time 10 \pm 0.5 seconds Flux Rosin resin methyl alcohol solvent (1 : 4)	MIL-STD-883E
8	Resistance to soldering heat	Pre-heat temperature 125°C Pre-heat time 60 to 120 sec. Test temperature 260 \pm 5°C Test time 5 \pm 1 sec.	MIL-STD-202F

2. ENVIRONMENTAL ENDURANCE

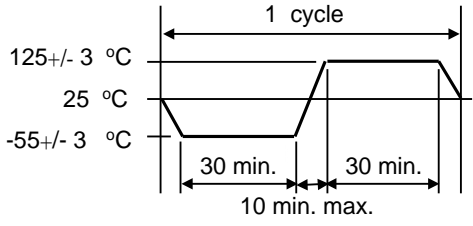
No.	Test Item	Test Methods	
9	High Temp. storage	+ 125°C \pm 3°C for 500 \pm 12 hours	MIL-STD-883E
10	Low Temp. storage	- 40°C \pm 3°C for 500 \pm 12 hours	
11	Thermal shock	Total 100 cycles of the following temperature cycle 	MIL-STD-883E
12	High Temp. & humidity	85°C \pm 3°C, RH 85%, 500 hours	JIS C5023



PACKING : (EIA-481-2)

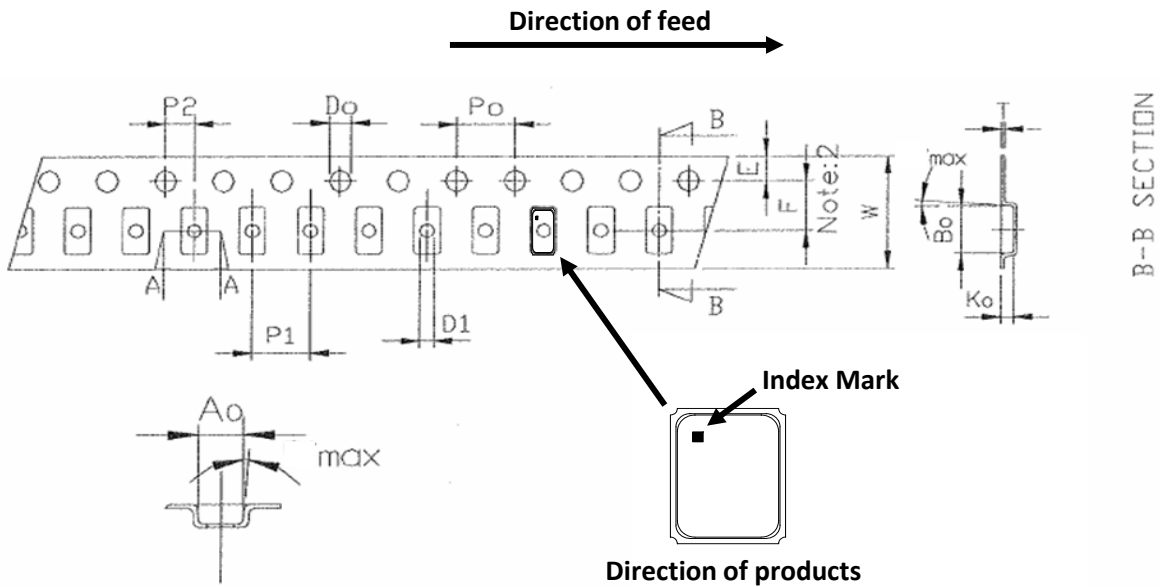

Dimension PKG Type	Unit : mm						
	A0	B0	K0	T	W	E	F
2520 TSX (8mm)	2.25±0.1	2.70±0.1	1.45±0.10	0.25±0.05	8±0.3	1.75±0.1	3.50±0.1
	P1	P2	D1	DO	PO		
	4±0.1	2±0.1	1±0.1	1.55±0.05	4±0.1		

Standard Reel Quantity is 3,000 pcs per reel.

THE INSPECTION FOR TAPE TENSION

ITEM		Defect	Method
Appearance	ALL	1.The tape is not coincidence 2.The bubble	Visual inspection
Tape Tension	8045、7050 6035-12mm 5032-12mm 3225-12mm	overstep 61±6g(55~67g)	Pull test
	3225-8mm	overstep 40±5g(35~45g)	
	2520-8mm	overstep 55±6g(49~61g)	
	2016-8mm	overstep 34±6g(28~40g)	
	1612-8mm	overstep 34±6g(28~40g)	
	6035-16mm 5032-16mm	overstep 60±6g(54~66g)	

REMARK : NA





SMD PRODUCT PACKING STANDARD

Out-going packing instruction

Reel Packing	Inner Packing	Carton
Name: Reel Standard: Diameter 18cm Material: Plastics Anti-Static Shielding Bag Standard: 205×250mm Material: APET/CPP	Name: Bubble Wrap Standard: 430×330+20mm Material: HDPE (15 reels enter)	Name: Carton Standard: 400×400×280mm Material: AB corrugated paper (4 bags enter)
		 

The label instruction

Label Drawing	Mark	Name of Article	Spec.	Size	Printing
	L1	条码标签 Bar Code Label (Chintz Paper)	1.Part No. 2.Lot No. 3.Q'ty 4.Freq	70x50mm	White
	L2	条码标签 Bar Code Label (Chintz Paper)	1.Part No. 2.Date Code 3.Q'ty 4.Freq	70x50mm	White

Remark

Specifications on the label is for the use of templates with different product specifications may vary.
If customer specified requirements for labels packaging, please provide the operation procedure.



SPECIFICATION OF THE ENVIRONMENT-RELATED SUBSTANCES

#	Range	Products	Packing Material
	Banned Substances	Maximum concentration ppm (mg/kg)	Maximum concentration ppm (mg/kg)
1	镉及镉化合物 Cadmium and cadmium compounds	100	100
2	铅及铅化合物 Lead and lead compounds	1000	100
3	汞及汞化合物 Mercury and mercury compounds	1000	100
4	六价铬化合物 Hexavalent-Chromium VI (Cr ⁺⁶)	1000	100
5	聚溴联苯 PBB Polybrominated biphenyls	1000	N/A
6	聚溴二苯醚 PBDE Polybrominated diphenyl ethers	1000	N/A
7	邻苯二甲酸二(2-乙基己基)酯 DEHP Di (2-ethylhexyl) phthalate	1000	N/A
8	邻苯二甲酸丁苄酯 BBP Butyl Benzyl Phthalate	1000	N/A
9	邻苯二甲酸二丁酯 DBP Dibutyl Phthalate	1000	N/A
10	邻苯二甲酸二异丁酯 DIBP Diisobutyl Phthalate	1000	N/A
11	氟(F)、氯(Cl)、溴(Br)、碘(I) Fluorine、Chlorine、Bromine、Iodine	900、900、900、900 注：Br+Cl < 1000	N/A
12	包装材料中重金属(汞、镉、六价铬、铅、PBB、PBDE)之总量 Heavy metals (mercury, cadmium, lead, Cr+6,PBB and PBDE) in packing materials	N/A	100 铅(Pb) + 镉(Cd) + 汞(Hg) + 六价铬(Cr+6) < 100ppm
13	高度关注物质 SVHC-Substances of Very High Concern	1000	N/A



惠伦晶体

FAITH LONG CRYSTAL