



Serial No. : 2017-1051

DATE : 2017/12/14

ITEM :

CRYSTAL RESONATOR

DSX211SH 26.000MHz

(TAIWAN) 1ZZHAE26000AB0L

(THAILAND) 1ZZNAE26000AB0L

If there is a change in this specifications,
the specification number may be changed.

RECEIPT

RECEIPT	
DATE	
RECEIVED	(signature) (name)

General Manufacturer of Quartz Devices

DAISHINKU CORP.

1389 Shinzaike, Hiraoka-cho, Kakogawa, Hyogo
675-0194 Japan

Phone (81)79-425-3141 Fax (81)79-425-1134
http://www.kds.info/index_en.htm

C.ENG.

T. Hanaki

ENG.

M. Nagaiishi

1. ELECTRICAL CHARACTERISTICS

(This test shall be performed under the conditions of temp.at $25 \pm 3^{\circ}\text{C}$, Relative Humidity 60% max.)

(1) NOMINAL FREQUENCY	26.000000 MHz		
(2) OVERTONE ORDER	Fundamental		
(3) LOAD CAPACITANCE(CL)	7.3 pF		
(4) FREQUENCY TOLERANCE	± 10 ppm max. (at $+25 \pm 3^{\circ}\text{C}$)		
(5) DRIVE LEVEL	10 ± 2 μW		
(6) SERIES RESISTANCE	100 Ω max. (at Series)		
(7) OPERATING TEMPERATURE RANGE	$-40 \sim +85^{\circ}\text{C}$		
(8) FREQUENCY CHARACTERISTICS OVER TEMPERATURE	± 15 ppm max. / $-40 \sim +85^{\circ}\text{C}$		(ref. to $+25^{\circ}\text{C}$)
(9) SHUNT CAPACITANCE	2.0 pF max.		
(10) INSULATION RESISTANCE	500 M Ω min. / DC $100 \pm 15\text{V}$		
(11) STORAGE TEMPERATURE RANGE	$-40 \sim +85^{\circ}\text{C}$		
(12) FREQUENCY AGING	± 15 ppm max. / 10 years		

2. CONSTRUCTION

(1) DIMENSIONS AND MARKING Refer to 4.

3. OTHER SPECIFICATIONS

(1) EMBOSS CARRIER TAPE & REEL Refer to 5.
 (2) PACKING Refer to 6.
 (3) REFLOW CONDITIONS (REFERENCE) Refer to 7.
 (4) LAND PATTERN (REFERENCE) Refer to 8.
 (5) RELIABILITY SPECIFICATION Refer to 9.~11.
 (6) OTHER HANDLING INSTRUCTIONS Refer to 12.

TITLE DSX211SH TYPE QUARTZ CRYSTAL SPECIFICATION	REMARK		
DATE 2017/12/14	SPEC. No. 1ZZNAE26000AB0L 1ZZHAE26000AB0L	REV.	PAGE 1 / 12

4. DIMENSIONS AND MARKING

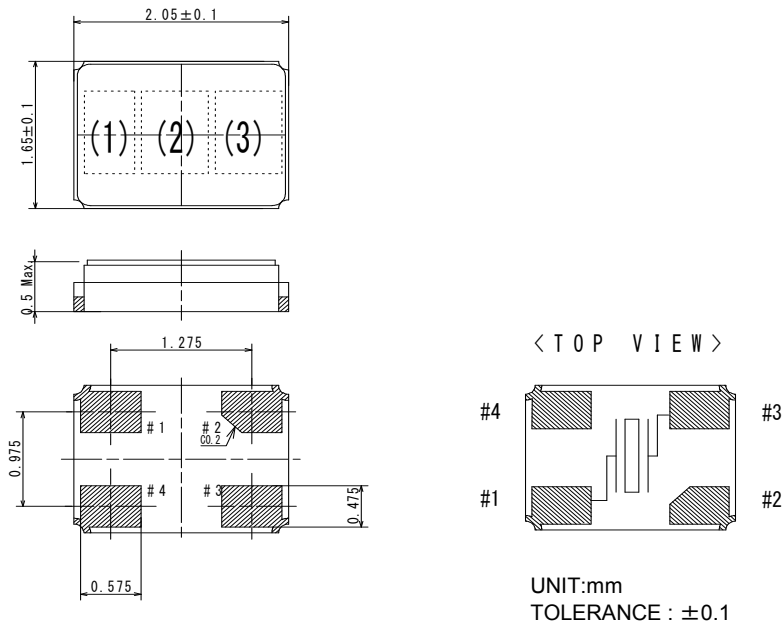

Figure-1

Logo(1) and Nominal Frequency (2) should be printed as follows by producing district

Made in THAILAND --> Spec. No.: 1ZZNAE26000AB0L , Logo : \overline{D} , Frequency: 26
 Made in TAIWAN --> Spec. No.: 1ZZHAE26000AB0L , Logo : D , Frequency: 26

* Made in THAILAND : Top Bar with D
 * Made in TAIWAN : Under Bar with 26

Nominal Frequency (2) = Mark two digits from upper decimal point
 (ex. 26.000000 MHz ----> 26)

Manufacturing lot No.(3)

Year : The last digit of the year

week : We gave the sequence of week numbers 01(first week) for production date.

there are starting from 1st of Jan. However,add '0' figure to the first week during the nine weeks.

The week means are from Sunday to Saturday.

(ex. 2017/12/14 ---> 750)

TITLE DSX211SH TYPE QUARTZ CRYSTAL SPECIFICATION		REMARK	
DATE 2017/12/14	SPEC. No. 1ZZNAE26000AB0L 1ZZHAE26000AB0L	REV.	PAGE 2 / 12

5. EMBOSS CARRIER TAPE & REEL

(1) Dimensions of embossed carrier tape

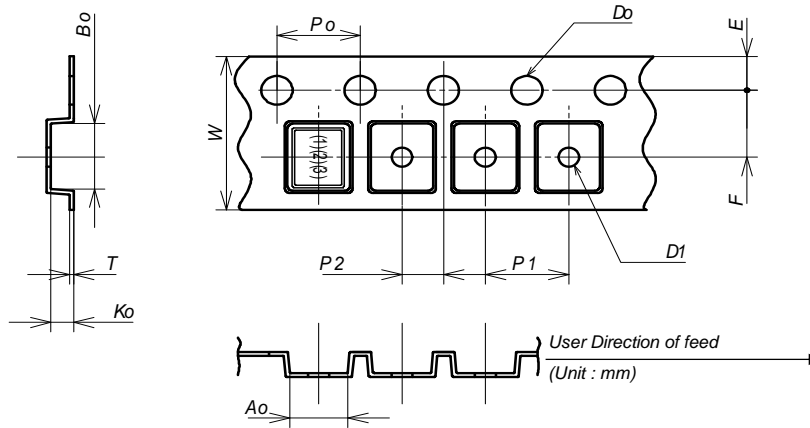

symbol	Ao	Bo	Ko	Po	P1	P2
spec.	1.9±0.1	2.3±0.1	0.65±0.1	4.0±0.1	4.0±0.1	2.0±0.05
symbol	E	F	D0	D1	W	T
spec.	1.75±0.1	3.5±0.05	Φ1.55±0.05	Φ1.1±0.05	8.0±0.2	0.25±0.02

(2) Dimensions of tape reel

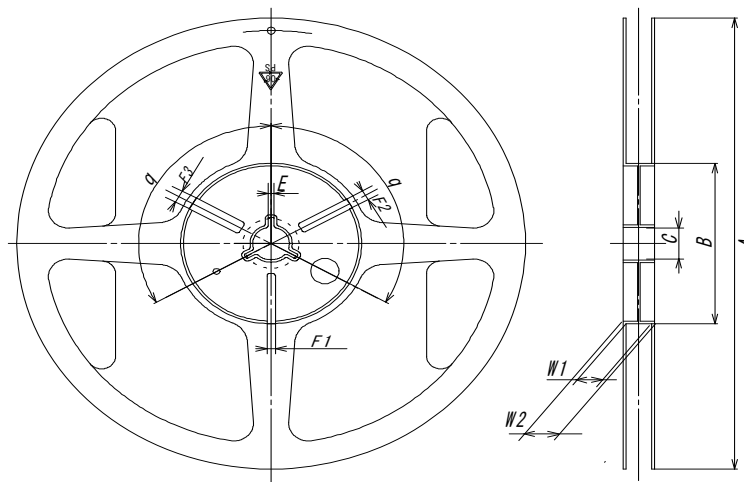

Figure-3

TITLE DSX211SH TYPE QUARTZ CRYSTAL SPECIFICATION		REMARK	
DATE	2017/12/14	SPEC. No.	REV.
		1ZZNAE26000AB0L 1ZZHAE26000AB0L	PAGE
			3 / 12

(UNIT:mm)

Products			DSX211SH
Item		Mark	Dimensions Angle
Flange	Diameter		A 180 Φ +0 -3
	Inside of Frange		W1 9.0 \pm 0.3
	Outside of Frange		W2 11.4 \pm 1
	Inside Diameter		B Φ 60 +1.0-0
Hub	Center Core Slit	Width	F1 3.0 +0.5 -0
			F2 4.0 +0.5 -0
			F3 5.0 +0.5 -0
	Angle		q 120°
	Spindle Diameter		C 13 Φ \pm 0.5
	Key Ditch	Width	E 2 \pm 0.5

(3) Storage condition

Temperature : +40 °C max.

Relative Humidity : 80% max.

(It is a guaranteed term because it obtains an excellent soldering: 6 months)

(4) Standard packing quantity

3,000 pcs/reel

(5) Material of the tape

Tape	Material
Carrier tape	PS Conductive
Cover tape	Polyester

TITLE		REMARK	
DSX211SH TYPE QUARTZ CRYSTAL SPECIFICATION			
DATE	SPEC. No.	REV.	PAGE
2017/12/14	1ZZNAE26000AB0L 1ZZHAE26000AB0L		4 / 12

(6) Label contents

- Type
- Our specification No.
- Your Part No.
- Lot No.
- Nominal Frequency
- Quantity
- Our Company Name

Stick a label on the each reel.

(7) Taping dimension

Leader	Cover-tape	The length of cover-tape in the leader is more than 400mm including empty embossed area.
	Carrier-tape	After all products were packaged, must remain more than twenty pieces or 400mm empty area, which should be sealed by cover-tape.
Terminal	Cover-tape	The tip of cover-tape shall be fixed temporary by paper tape and roll around the core of reel one round.
	Carrier-tape	The empty embossed area which are sealed by cover-tape must remain more than 40mm.

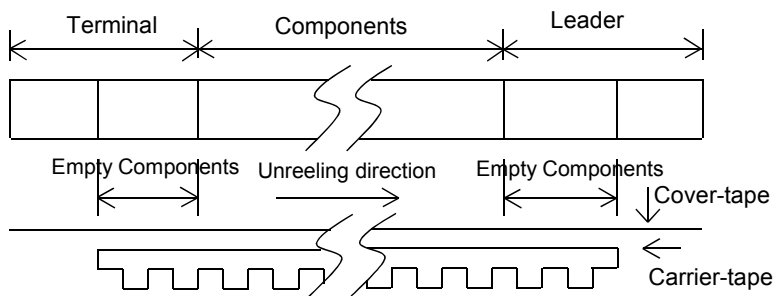

Figure-4

(8) Joint of tape

The carrier-tape and cover-tape should not be jointed.

(9) Release strength of cover tape

It has to between 0.1 ~ 0.7N under following condition.

- Pulling direction 165 ~ 180 °
- Speed 300mm/min
- Otherwise unless specified.

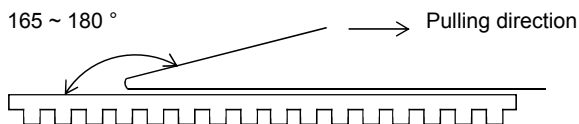

Figure-5

Other standards shall be based on JIS C 0806 .1990.

TITLE DSX211SH TYPE QUARTZ CRYSTAL SPECIFICATION		REMARK	
DATE 2017/12/14	SPEC. No. 1ZZNAE26000AB0L 1ZZHAE26000AB0L	REV.	PAGE 5 / 12

6. PACKING

(1) STORAGE METHOD

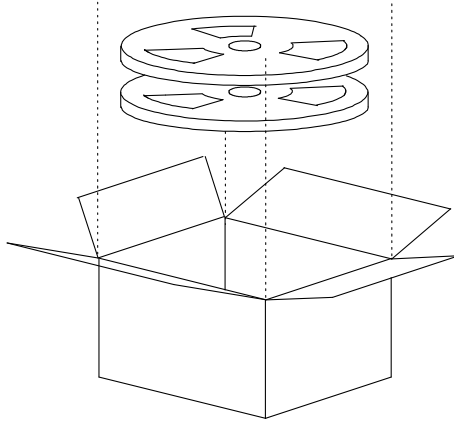

Figure-6

(2) BOX SIZE

From lot size packingsize shall be changed.
 In the upper and lower part and the opening in box it shall be protected products using aircushion sheets.

TITLE DSX211SH TYPE QUARTZ CRYSTAL SPECIFICATION		REMARK	
DATE 2017/12/14	SPEC. No. 1ZZNAE26000AB0L 1ZZHAE26000AB0L	REV.	PAGE 6 / 12

7. REFLOW CONDITIONS (REFERENCE)

During the solder reflow process, please complete within following temperature, period.
 Reflow soldering shall be allowed only 2 times.

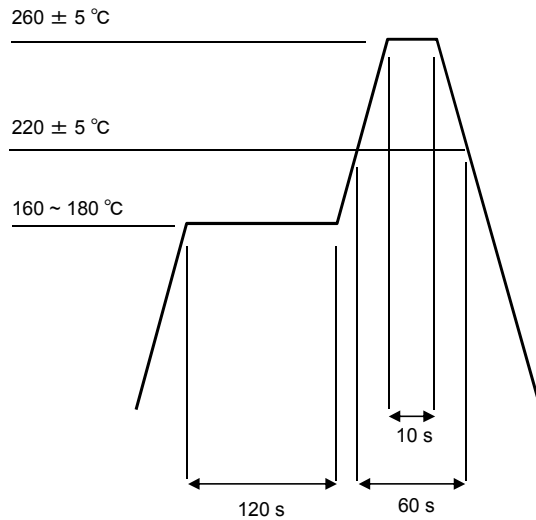
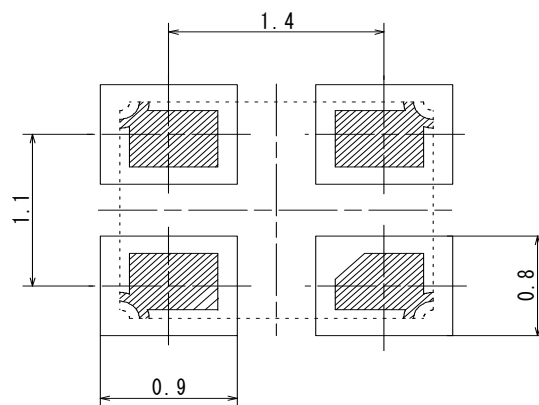

Figure-7

HANDSOLDERING METHOD : +350 °C max. , 3s max. Each terminal once
 (Please take care so that a soldering iron should not touch a product directly.)

8. LAND PATTERN (REFERENCE)



unit : mm

Figure-8

TITLE DSX211SH TYPE QUARTZ CRYSTAL SPECIFICATION		REMARK	
DATE 2017/12/14	SPEC. No. 1ZZNAE26000AB0L 1ZZHAE26000AB0L	REV.	PAGE 7 / 12

9. MECHANICAL ENDURANCE

(1) SHOCK (NATURAL DROP)

After the following test, parts shall conform specification 11.B.
 Drop on 3 times from height of 50cm onto min. 30mm thickness hard wooden board.

(2) VIBRATION

After the following test, parts shall conform specification 11.B.
 and no abnormal appearance shall be observed.

- Frequency of Vibration : 10 ~ 55 Hz
- Amplitude(p-p) : Sine waves of 0.8mm
- Vibration axis : X.Y.Z
- Vibration period : 2h for each axis

(3) SEAL

Less than 1.0×10^{-8} Pa m³/s by Helium leak detector.
 Also, no serial bubble is observed by Fluorocarbon tests.

(4) SOLDERABILITY

After the following test, more than 95% of terminal shall be covered by new solder.
 3 ± 0.5 s dip in +245 ± 5 °C solder.
 (Solder composition : Sn-3Ag-0.5Cu) (Use rosin type flux for solder.)

(5) RESISTANCE TO SOLDERING HEAT (REFLOW)

48h past at room temperature from following test, parts shall conform specification 11.B.
 perform the attached Reflow conditions to reference.

(6) RESISTANCE TO SOLDERING HEAT (HAND SOLDERING METHOD)

48h past at room temperature from following test, parts shall conform specification 11.B.
 +350 °C max , 3s max. Each terminal once.

(7) SUBSTRATE BENDING

After the following test, parts shall conform specification 11.B.
 and no abnormality shall be observed in external appearance and sealing
 tightness and others shall be based on ET-7403 of EIAJ.

Mount the specimen on substrate.

Apply the following pressure

- Direction : see right figure
- Speed : about 0.5 mm/s
- Hours : 5 ± 1 s
- Amount of substrate : 3 mm max.

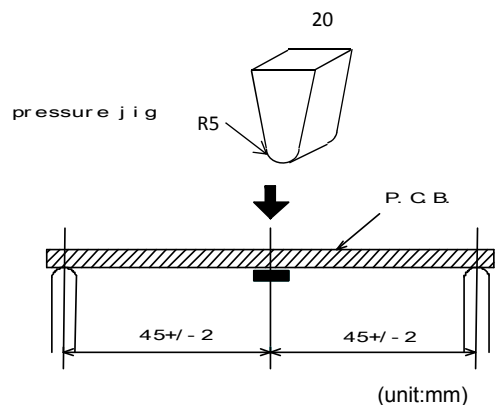

TIT 2 DSX211SH TYPE QUARTZ CRYSTAL SPECIFICATION		REMARK	
DATE	SPEC. No.	REV.	PAGE
2017/12/14	1ZZNAE26000AB0L 1ZZHAE26000AB0L		8 / 12

(8) SHEAR

After the following test, parts shall conform specification 11.B.
and no abnormality shall be observed in external appearance and sealing
tightness and others shall be based on ET-7403 of EIAJ.

Mount the specimen on substrate.

Apply the following pressure

- Weight : 10 N
- Hours : 10 ± 1 s
- Direction : see right figure

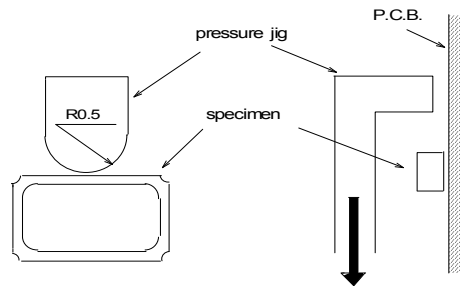

(9) BODY STRENGTH

After the following test, parts shall conform specification 11.B.
and no abnormality shall be observed in external appearance and sealing
tightness and others shall be based on ET-7403 of EIAJ.

Mount the specimen on substrate.

Apply the following pressure

- Weight : 5N
- Hours : 10 ± 1 s
- Direction : see right figure

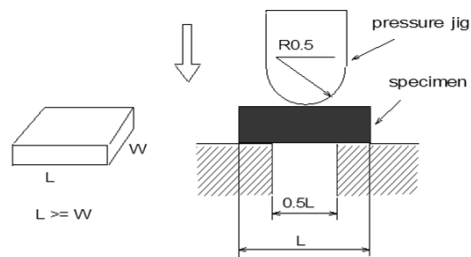

TITLE DSX211SH TYPE QUARTZ CRYSTAL SPECIFICATION		REMARK	
DATE 2017/12/14	SPEC. No. 1ZZNAE26000AB0L 1ZZHAE26000AB0L	REV.	PAGE 9 / 12

10. ENVIRONMENTAL ENDURANCE

(1) LOW TEMPERATURE

2h past at room temperature after following test, parts shall conform specification 11.B.
240h , -40 ± 3 °C.

(2) HUMIDITY

2h past at room temperature after following test, parts shall conform specification 11.B.
240h , $+60 \pm 2$ °C , relative humidity 90 ~ 95%.

(3) HIGH TEMPERATURE

2h past at room temperature after following test, parts shall conform specification 11.B.
240h , $+85 \pm 2$ °C.

(4) TEMPERATURE CYCLE

2h past at room temperature after 25 cycles of followingtest, parts shall conform specification 11.B.

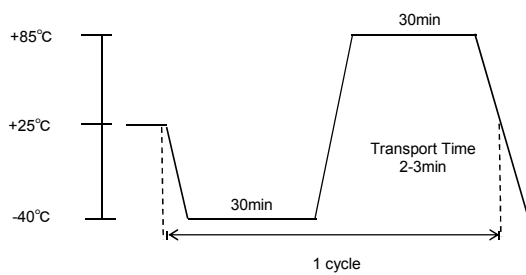

11. SPECIFICATION

Frequency Variation and Equivalent Resistance shall be within Table below after the reliability test.

Spec.	Frequency Variation	Equivalent Resistance
A	± 2 ppm	± 15 % or 2.0 Ω max. (Use larger specification)
B	± 5 ppm	± 20 % or 3.0 Ω max. (Use larger specification)

TITLE DSX211SH TYPE QUARTZ CRYSTAL SPECIFICATION		REMARK	
DATE 2017/12/14	SPEC. No. 1ZZNAE26000AB0L 1ZZHAE26000AB0L	REV.	PAGE 10 / 12

12. DSX211SH TYPE QUARTZ CRYSTAL HANDLING INSTRUCTIONS

(1) SOLDERING

Please perform the attached Reflow conditions to reference within 2 times.

(2) MOUNT

Crystal products are designed to be compatible with automatic mounting.
Be sure to have a mounting test in advance by using the actual mounting machine and check that the characteristics of the products are not damaged by the automatic mounting.

In the process where the board is warped, such as board separation process, be careful that the warping does not influence the characteristics and soldering of crystal products.

Since mounting by Ultrasonic welding and processing have a possibility of an excessive vibration spreading inside a crystal resonator and becoming the cause of characteristic deterioration and not oscillating, it does not recommend.

(3) WASHING

About use of the washing liquid of a basin system, an alcoholic system, and a chlorofluorocarbon-replacing material system, it is checking that it is satisfactory. However please consult in advance about other washing liquid. Although the check about ultrasonic washing is performed, since it is an examination with a simple substance, the check for the second time by the use state is recommended.

(4) THE CAUTIONS ON USE

The piece of crystal it is processed very smaller than the conventional thing inside DSX211SH series crystal unit may be damaged, if excessive excitation electric power is applied.

Please use it below with the value specified on a catalog and specifications. Please refrain from forming patterns between crystal land pattern's since there is a possibility to cause crack in base.

(5) HANDLING OF A PRODUCT

DSX211SH series has sufficient intensity to fall and vibration. However when too much shock is added according to a certain cause, the use after a characteristic check is recommended.

(6) STORAGE

Since the soldering nature of a terminal may be degraded, please avoid storage in high temperature and a humid place.

Please keep it in the place which direct rays do not hit and dew condensation does not generate.

TITLE DSX211SH TYPE QUARTZ CRYSTAL SPECIFICATION	REMARK		
DATE 2017/12/14	SPEC. No. 1ZZNAE26000AB0L 1ZZHAE26000AB0L	REV.	PAGE 11 / 12

