

1. Scope

The specifications are applicable to the crystal unit to be supplied by CITIZEN FINEDEVICE CO., LTD.

- 1.1 Any question arising out of the specifications or any matter undefined shall be settled through mutual consultations between both parties.
- 1.2 The specifications does not include product testing data.
The contents except electrical specifications and dimensions are subject to change without prior notice.
- 1.3 The product is not intended to be incorporated in any equipment requiring extremely high reliability such as life supporting system.

2. Electrical Specifications

2.1 Nominal Frequency	32.768 kHz
2.2 Operating Temperature Range	-40 ~ +85°C
2.3 Storage Temperature Range	-55 ~ +125°C
2.4 Frequency Tolerance	±20ppm Max. at 25°C
2.5 Frequency Tolerance over Operating Temperature Range	Turnover Temp.; 25 ± 5°C Temp.Coefficient: -0.034 ± 0.006ppm/°C ²
2.6 Equivalent Series Resistance	70kΩ Max. at 25°C
2.7 Insulation Resistance	500MΩ Min./DC100V ± 15V

3. Test Conditions

3.1 Load Capacitance	12.5pF This Load Capacitance has been fixed on customer's request.
3.2 Level of Drive	1μW Max.

4. Mechanical and Environmental Tests

Test Name	Test Conditions	Criteria No.
1. Mechanical Tests		
1-1 Shock	Drop 3 times from the height of 75 cm onto hard wooden board with thickness of 3 cm.	A
1-2 Vibration	Vibration Frequency : 10 to 500 Hz, 1.5mm, full wave, or acceleration 10G, Cycle : 1.5 minutes, Direction : X.Y.Z. Time : 2 hours in each direction, for 6 hours in total.	A
1-3 Strength	Weight 9.8N on the center of sample with R 0.5 bar 10 seconds.	C
1-4 Solderability	After applying RMA flux, dip in solder. Dipping Time : 5 ± 0.5 seconds. Soldering Temperature : $230 \pm 5^\circ\text{C}$.	D
1-5 Reflow Soldering Heat Resistance	See Fig.1 reflow condition.	B
1-6 Sealing Tightness	Leak rate shall be measured by using Helium Leak Detector.	E
2. Environmental Tests		
2-1 Storage In Low Temperature	Expose the sample in an inoperative mode to 500 hours at -40°C .	A
2-2 Storage In High Temperature	Expose the sample in an inoperative mode to 500 hours at $+85^\circ\text{C}$.	B
2-3 Humidity	Expose the sample in an inoperative mode to 500 hours at $+65^\circ\text{C}$, and 95%RH.	B
2-4 Thermal Shock	Subject the sample to 5 temperature variation cycles at -40°C for 30 minutes and $+100^\circ\text{C}$ for the next 30 minutes in each cycle.	A

Criteria

Criteria No.	Criteria
A	Any variation between the pre- and post-test frequencies shall remain within ± 5 ppm. The equivalent series resistance shall remain within its specified tolerance range after the post-test.
B	Any variation between the pre- and post-test frequencies shall remain within ± 10 ppm. The equivalent series resistance shall remain within its specified tolerance range after the post-test.
C	After each test, no visible damage, nor the hermetic seal break down.
D	At least 90% of each dipped area shall be covered by fresh solder.
E	$1 \times 10^{-2} \mu\text{Pa} \cdot \text{m}^3/\text{s}$ Max.

※ Measurements should be taken place at $25 \pm 2^\circ\text{C}$ after each test, the samples shall be left at 25°C for one to two hours.

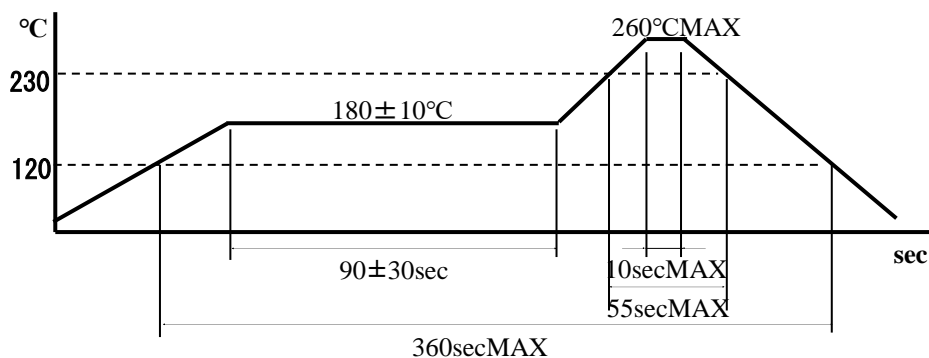
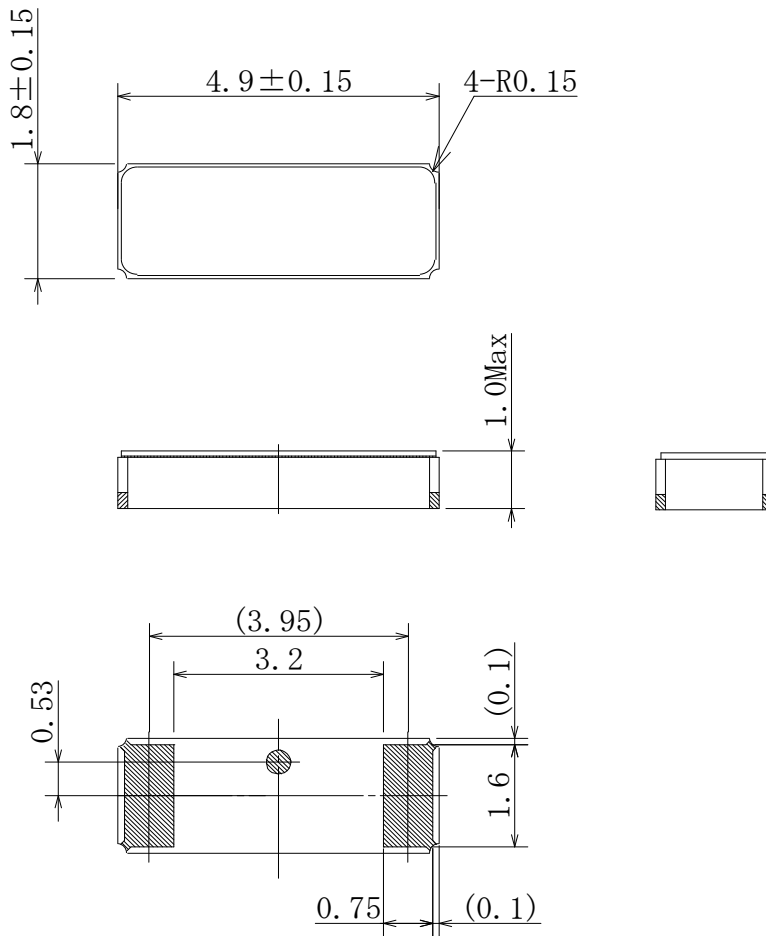

Fig.1

5. Dimensions

(unit:mm)



6. Solder Pad Layout

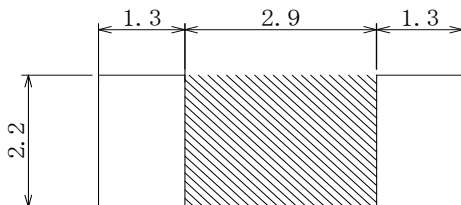

*Do not wire on shades portion.

7. Marking Standards



C: Manufacture's ID Code

y: The last digit of production year.

m: Production month.(See Table 1)

###: Lot.No.

Table 1

Month	1	2	...	9	10	11	12
Code	1	2	...	9	X	Y	Z

点封止位置の記載なし

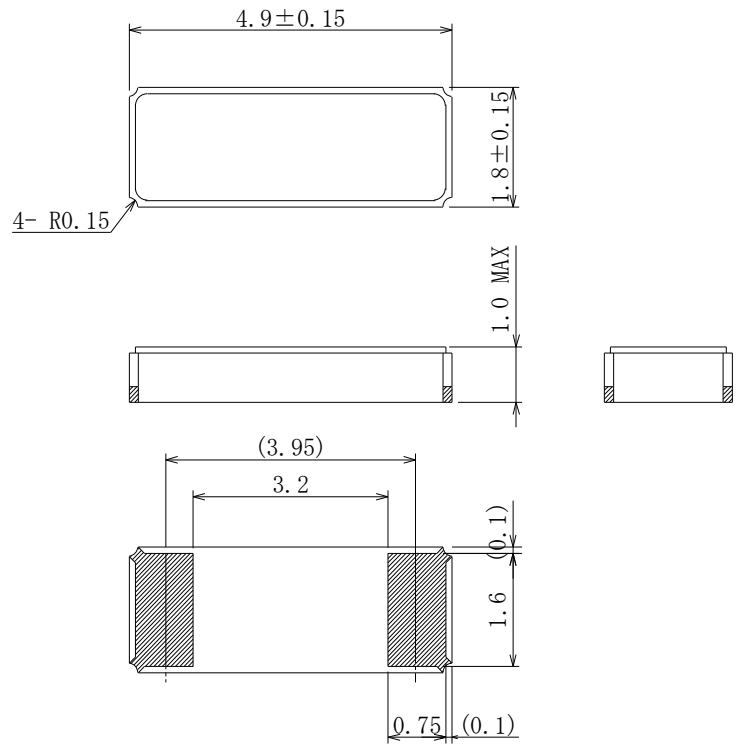

Table 1

Month	1	2	...	9	10	11	12
Code	1	2	...	9	X	Y	Z

8. Tape and Reel Packaging

(unit:mm)

(1) Taping Specification

Conforming to JIS C 0806-3

【Tape Dimensions】

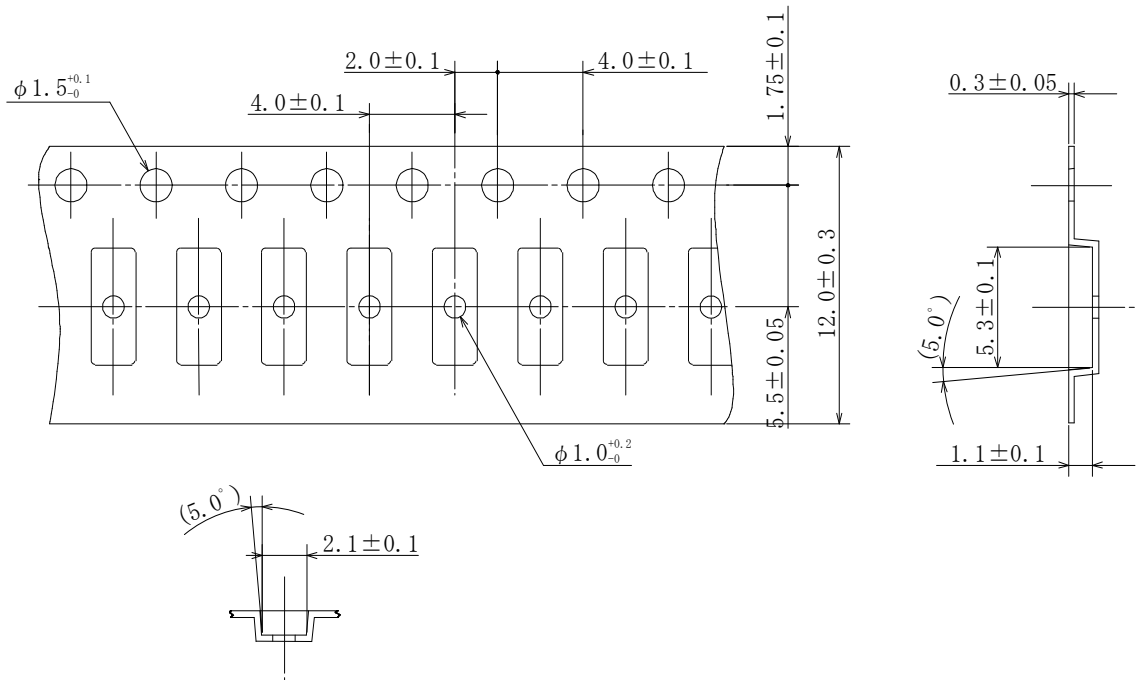

【Reel Dimensions】

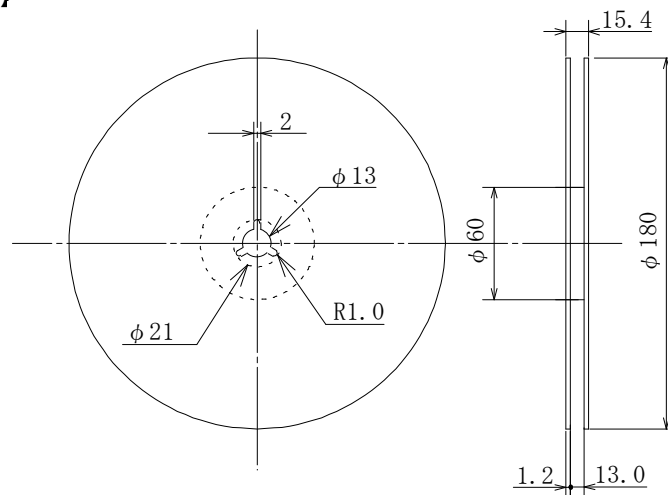

Material(Carrier tape) : Black conductive PS
 Material (Cover tape) : Clear PE
 Material (Reel) : PS

【Packing】

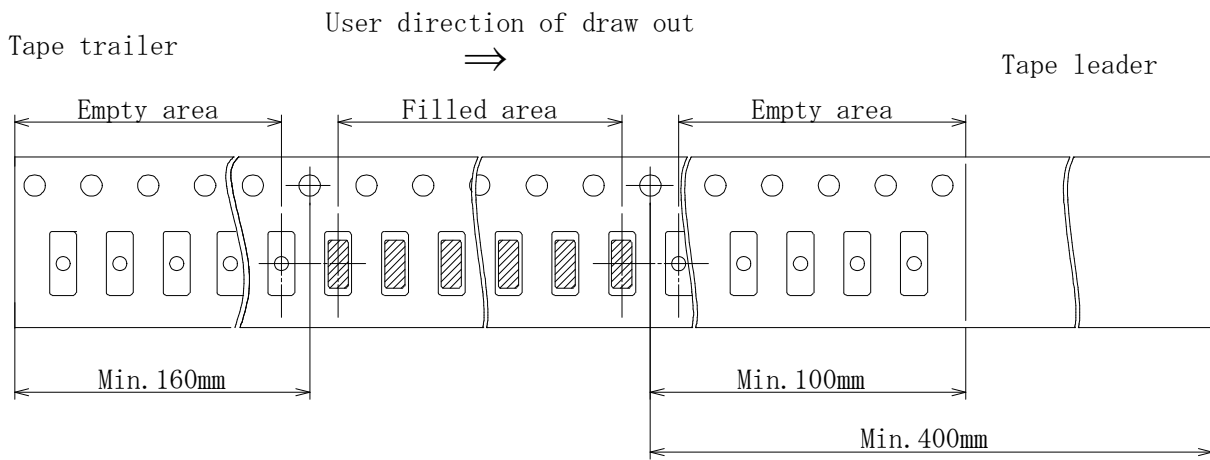

(2) Inner Carton

【Items shown on the Bar Code Label】

- * Customer P/N
- * Lot.No.
- * CITIZEN P/N
- * Ctl No
- * Date Code
- * Quantity
- * Country Code

yy : The last 2 digits of shipment year
ww : Week Code

CN = China

【Reel】

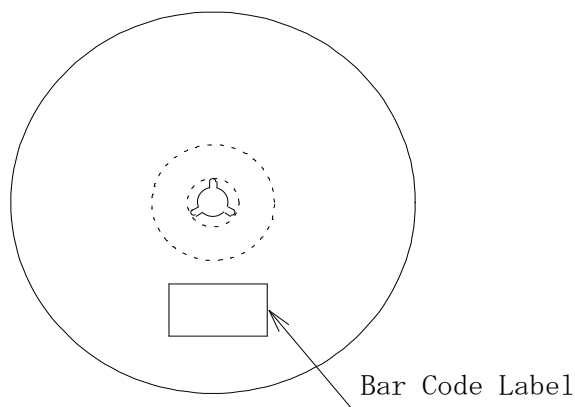

【Inner Carton for 1 reel】

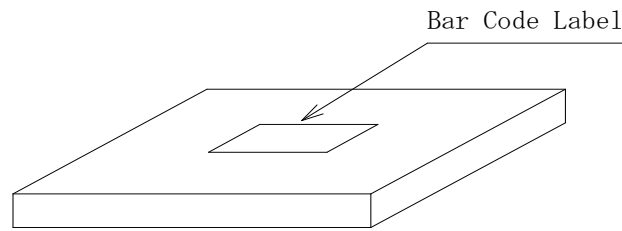

(3)Quantity

3000pcs/reel

9. Storage Condition

9.1 Storage Condition	Temperature	5 ~ 35°C
	Humidity	45 ~ 75%
9.2 Warranty Period	Twelve months	

10. Manufacturer

MASTER CROWN ELECTRONICS (WUZHOU) LIMITED.
No8 BUILDING 137.XINXING ER ROAD, WUZHOU, GUANGXI, CHINA
TEL : +86-774-3863148

Country of Origin :CHINA

* This manufacture is under the control of CITIZEN FINEDEVICE CO., LTD.

11. Ozone Depleting Substance (ODS)

This Product does not use the classI ODS for any of production processes or for component parts.

12. Handling Notes

12-1 When dropped by mistake

The crystal products are designed and manufactured to satisfy the test criteria for shock and vibration. Be sure, however, to check the product's performance before use in the event that they receive excessive shock, for example, by dropping onto the floor.

12-2 Mounting crystal units onto circuit board

When using an automatic loading mounter, test and confirm that no damage has been caused to the characteristics of crystal units before mounting. In case that the boards need to be separated after mounting crystal units, be careful that the bending stress does not affect the product characteristics or solder junction areas.

12-3 Cleaning

- (1) Crystal products may be affected and destroyed at worst by ultrasonic cleaning. Be sure that your cleaning process does not affect the functionality of crystal product prior to use.
- (2) The use of inappropriate cleaning fluid may cause damages to crystal products. Please be sure to check suitability of the cleaning fluid in advance.

12-4 Storage

Storage of crystal products under higher temperature or high humidity for a long term may affect frequency stability or solderability. Be sure to store the products under the normal temperature and humidity without exposing to direct sunlight and dew condensation. Storage period should be within 6 months if possible, and mount the products as soon as possible after unpacking.

12-5 Replacement

If the defect is caused by our company within 12 months from the delivery time, we provide the replacement free of charge.

13. Note

- 13-1 CITIZEN FINEDEVICE CO., LTD. does not assume any liability for any defect arising from improper use of the product beyond the specifications provided.
- 13-2 CITIZEN FINEDEVICE CO., LTD. does not assume any liability for any damage, loss or infringement of third partys' rights including industrial property rights or other related rights, which may result from the use of the product in this specifications.
- 13-3 The product in this specifications is designed to be used for general electronic equipment, and not intended to be incorporated in any medical equipment or safety control device requiring high reliability, where product defect may threaten human life and body, or may damage a property. CITIZEN FINEDEVICE CO., LTD. may decline your purchase request if the product is planned to be used for such applications, and does not assume any liability for any damages or loss arising from the use for the applications.