

Application Manual

Real Time Clock Module

RX8010SJ

Preliminary

NOTICE

- This material is subject to change without notice.
- Any part of this material may not be reproduced or duplicated in any form or any means without the written permission of Seiko Epson.
- The information about applied circuitry, software, usage, etc. written in this material is intended for reference only. Seiko Epson does not assume any liability for the occurrence of infringing on any patent or copyright of a third party. This material does not authorize the licensing for any patent or intellectual copyrights.
- When exporting the products or technology described in this material, you should comply with the applicable export control laws and regulations and follow the procedures required by such laws and regulations.
- You are requested not to use the products (and any technical information furnished, if any) for the development and/or manufacture of weapon of mass destruction or for other military purposes. You are also requested that you would not make the products available to any third party who may use the products for such prohibited purposes.
- These products are intended for general use in electronic equipment. When using them in specific applications that require extremely high reliability, such as the applications stated below, you must obtain permission from Seiko Epson in advance.
 - / Space equipment (artificial satellites, rockets, etc.) / Transportation vehicles and related (automobiles, aircraft, trains, vessels, etc.) / Medical instruments to sustain life / Submarine transmitters / Power stations and related / Fire work equipment and security equipment / traffic control equipment / and others requiring equivalent reliability.
- All brands or product names mentioned herein are trademarks and/or registered trademarks of their respective.

Contents

1. Overview.....	1
2. Block Diagram	1
3. Terminal description	2
4. External Dimensions.....	3
5. Absolute Maximum Ratings.....	4
6. Recommended Operating Conditions.....	4
7. Frequency Characteristics.....	4
8. Electrical Characteristics	5
9. Matters that demand special attention on use	7
10. Reference information	9
11. Application notes	10
12. Overview of Functions and Description of Registers.....	11
12.1. Overview of Functions	11
12.2. Register table.....	12
12.3. Description of registers	13
13. How to use.....	15
13.1. Clock calendar explanation.....	15
13.2. Fixed-cycle Timer Interrupt Function.....	15
13.3. Alarm Interrupt Function	20
13.4. Time Update Interrupt Function	22
13.5. Frequency stop detection function	23
13.6. FOUT function [clock output function].....	23
13.7. Reading/Writing Data via the I ² C Bus Interface	24

Low current consumption
SERIAL-INTERFACE REAL TIME CLOCK MODULE

RX8010 SJ

- Built in frequency adjusted 32.768-kHz crystal unit.
- Real-time clock function : Clock/calendar function, Long timer function, alarm interrupt function, etc.
- User RAM : Built in 128 bit RAM
- 32.768 kHz output function : C-MOS or N-ch Open drain
- Interface type : I²C-Bus
- Interface voltage range : 1.6 V ~ 5.5 V
- Timekeeper voltage range : 1.1 V ~ 5.5 V
- Backup current consumption : 160 nA_{Typ} / 3 V

The I²C-Bus is a trademark of NXP Semiconductors.

1. Overview

This is a real-time clock module of the serial interface system that incorporates a 32.768 kHz crystal oscillator. The real-time clock function incorporates not only a calendar and clock counter for the year, month, day, day of the week, hour, minute, and second, but also a time alarm, interval timer, and time update interruption, among other features. All of these many functions are implemented in a thin, compact SOP package, which makes it suitable for various kinds of mobile telephones and other small electronic devices.

2. Block Diagram

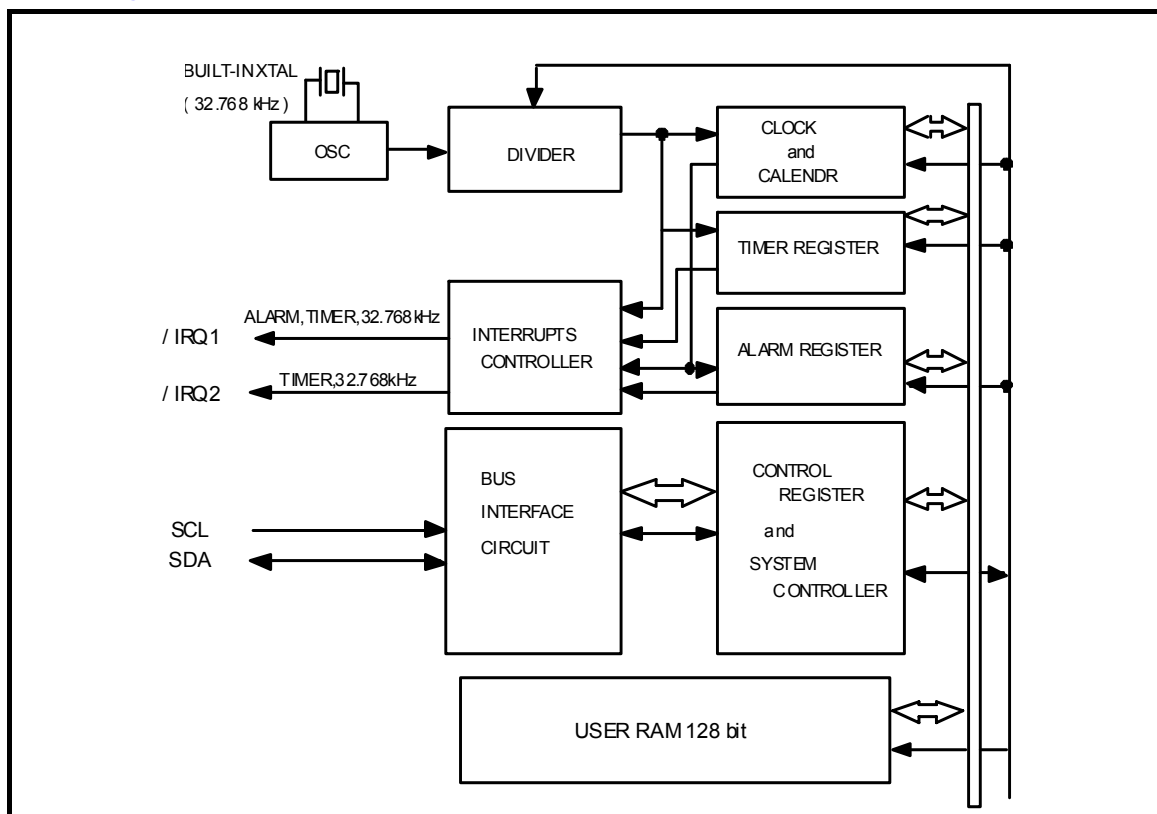

3. Terminal description

3.1. Terminal connections

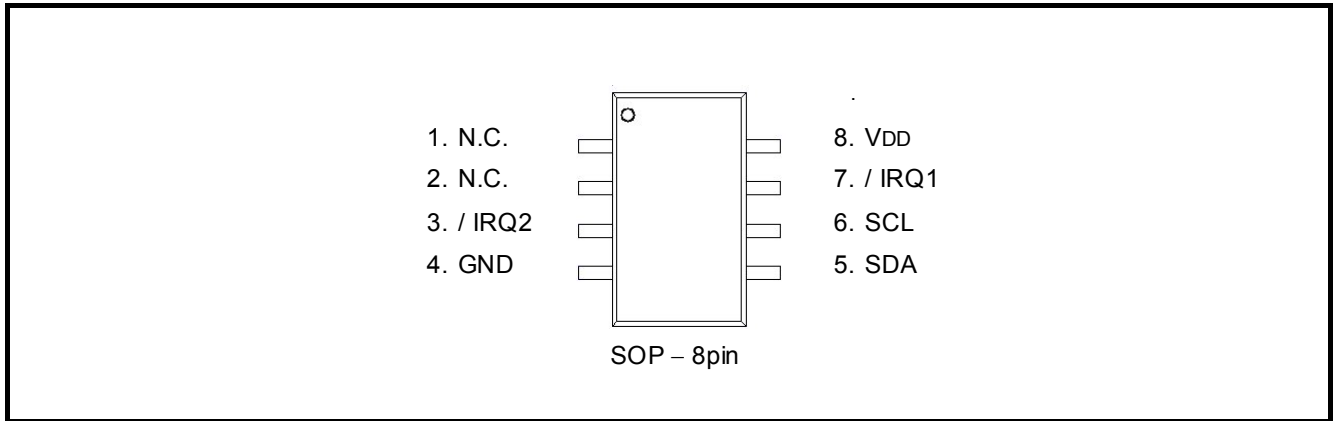

3.2. Pin Functions

Signal name	I/O	Function
SCL	Input	This is a shift clock input pin for serial data transmission.
SDA	Input/Output	This is the data input/output pin for serial data transfer.
/IRQ1	Output	This pin outputs interrupt signals ("L" level) for alarm, timer, time update, and 32.768kHz. This is an N-ch open-drain output.
/IRQ2	Output	This pin outputs interrupt signals ("L" level) for timer and 32.768kHz. This is an C-MOS output.
VDD	Supply	This is a power-supply pin.
GND	Supply	This pin is connected to a ground.

Note: Input pins are able to input up to 5.5V regardless of VDD applied voltage.

Note: Open drain pins are able to Pull-up to 5.5V regardless of VDD applied voltage.

Note: Connect a bypass capacitor rated at least 0.1µF between power supply pins and GND pin.

4. External Dimensions

4.1. External Dimensions

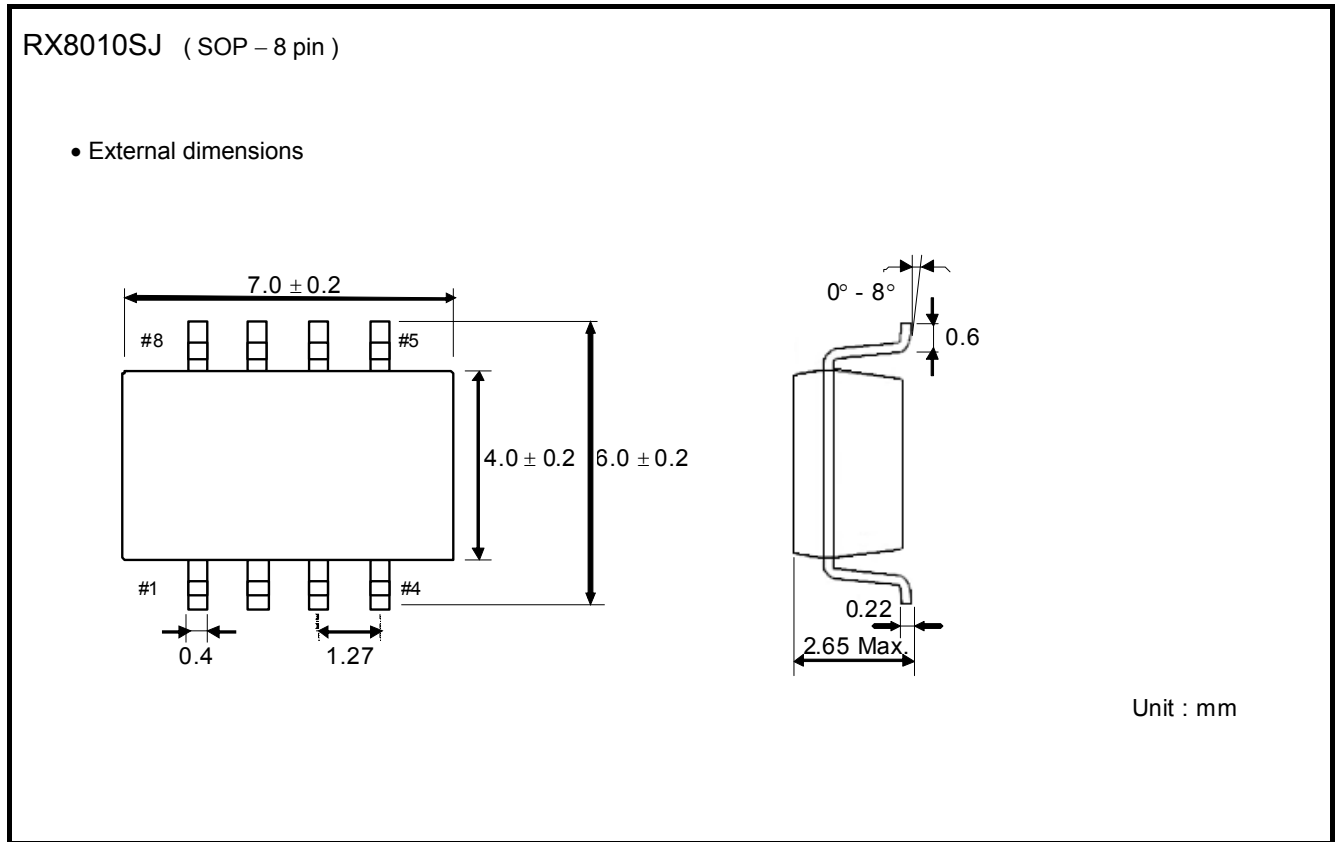

5. Absolute Maximum Ratings

GND = 0 V

Item	Symbol	Condition	Rating	Unit
Supply voltage	V _{DD}	Between V _{DD} and GND	-0.3 ~ +6.5	V
Input voltage	V _{IN}	SCL, SDA	-0.3 ~ +6.5	V
Output voltage 1	V _{OUT1}	/IRQ2	-0.3 ~ V _{DD} +0.3	V
Output voltage 2	V _{OUT2}	SDA, /IRQ1	-0.3 ~ +6.5	V
Storage temperature	T _{STG}	When stored separately, without packaging	-55 to +125	°C

6. Recommended Operating

*Unless otherwise specified, GND = 0 V, Ta = -40 °C to +85 °C

Item	Symbol	Condition	Min.	Typ.	Max.	Unit
Operating supply voltage	V _{ACC}	-	1.6	3.0	5.5	V
Clock supply voltage	V _{CLK}	-	1.1	3.0	5.5	V
Backup power supply Low voltage detection	V _{LOW}	-			1.10	V
Applied voltage when OFF	V _{PUP}	SDA, /IRQ1pin			5.5	V
Operating temperature	T _{OPR}	No condensation	-40	+25	+85	°C

*Minimum value of Clock supply voltage V_{CLK} is the timekeeping continuation lower limit value that initialized RX8010 in operating supply voltage V_{ACC}.

7. Frequency Characteristics

*Unless otherwise specified, GND = 0 V, Ta = -40 °C to +85 °C

Item	Symbol	Condition	Min.	Typ.	Max.	Unit
Output frequency	f _o			32.768 (Typ.)		kHz
Frequency/voltage characteristics	$\Delta f / f$	Ta = +25 °C V _{DD} = 3.0 V		5 ± 23 (*1)		× 10 ⁻⁶
Frequency/voltage characteristics	f / V	Ta = +25 °C V _{DD} = 2.0 V ~ 5.0 V	-2		+2	× 10 ⁻⁶ / V
Frequency/temperature characteristics	T _{op}	Ta = -20 °C ~ +70 °C V _{DD} = 3.0 V ; +25 °C reference	-120		+10	× 10 ⁻⁶
Oscillation start time	t _{STA}	Ta = ±0 °C ~ +50 °C V _{DD} = 1.6 V ~ 5.5 V			1.0	s
		Ta = -40 °C ~ +85 °C V _{DD} = 1.6 V ~ 5.5 V			3.0	s
Aging	f _a	Ta = +25 °C, V _{DD} = 3.0 V ; first year	-5		+5	× 10 ⁻⁶ / year

*1) The monthly error is equal to one minute. (excluding offset)

8. Electrical Characteristics

8.1. DC characteristics

*Unless otherwise specified, GND = 0 V , Ta = -40 °C to +85 °C

8.1.1. DC characteristics (1)

*Unless otherwise specified, GND = 0 V , VDD = 1.6 V ~ 5.5 V , Ta = -40°C ~ +85°C

Item	Symbol	Condition		Min.	Typ.	Max.	Unit
Current consumption (1)	IDD1	Input pins are "L" fCLK = 0 Hz, /IRQ1,2 = OFF	VDD = 5 V			350	nA
Current consumption (2)	IDD2		VDD = 3 V		160	320	nA
Current consumption (3)	IDD3	fCLK = 0 Hz, /IRQ1 = OFF, /IRQ2 : 32.768 kHz ON , CL = 0 pF	VDD = 5 V		2.5	3.3	μA
Current consumption (4)	IDD4		VDD = 3 V		1.5	2.1	
Current consumption (5)	IDD5	fCLK = 0 Hz, /IRQ1 = OFF, /IRQ2 : 32.768 kHz ON , CL = 15 pF	VDD = 5 V		5.5	7.0	μA
Current consumption (6)	IDD6		VDD = 3 V		3.0	4.0	
High-level input voltage	VIH	SCL,SDA pin		0.8 × VDD		5.5	
Low-level input voltage	VIL	SCL, SDA pin		GND - 0.3		0.2 × VDD	V
High-level output voltage	VOH1	/IRQ2 pin	VDD=5 V, IOH=-1 mA	4.5		5.0	V
	VOH2		VDD =3 V, IOH=-0.5 mA	2.7		3.0	
Low-level output voltage	VOL1	/IRQ2 pin	VDD =5 V, IOL=1 mA	GND		GND +0.5	V
	VOL2		VDD =3 V, IOL=0.5 mA	GND		GND +0.3	
	VOL4	/IRQ1 pin	VDD =5 V, IOL=1 mA	GND		GND +0.25	V
	VOL5		VDD =3 V, IOL=1 mA	GND		GND +0.4	
Input leakage current	ILK	Input pin, VIN = VDD or GND		-0.1		0.1	μA
Output leakage current	IOZ	Input pin, VOUT = VDD or GND		-0.1		0.1	μA

* The current consumption are target specifications.

8.2. AC characteristics

8.2.1. AC characteristics(1)

*Unless otherwise specified, GND = 0 V, VDD= 1.6 V ~ 5.5 V, Ta = -40°C ~ +85°C

Item	Symbol	Standard-Mode (fSCL=100kHz)		Fast-Mode (fSCL=400kHz)		Unit
		Min.	Max.	Min.	Max.	
SCL clock frequency	fSCL		100		400	kHz
Start condition setup time	tSU;STA	4.7		0.6		μs
Start condition hold time	tHD;STA	4.0		0.6		μs
Data setup time	tSU;DAT	250		100		ns
Data hold time	tHD;DAT	0		0		ns
Stop condition setup time	tSU;STO	4.0		0.6		μs
Bus idle time between start condition and stop condition	tBUF	4.7		1.3		μs
Time when SCL = "L"	tLOW	4.7		1.3		μs
Time when SCL = "H"	tHIGH	4.0		0.6		μs
Rise time for SCL and SDA	tr		1.0		0.3	μs
Fall time for SCL and SDA	tf		0.3		0.3	μs
Allowable spike time on bus	tSP		50		50	ns

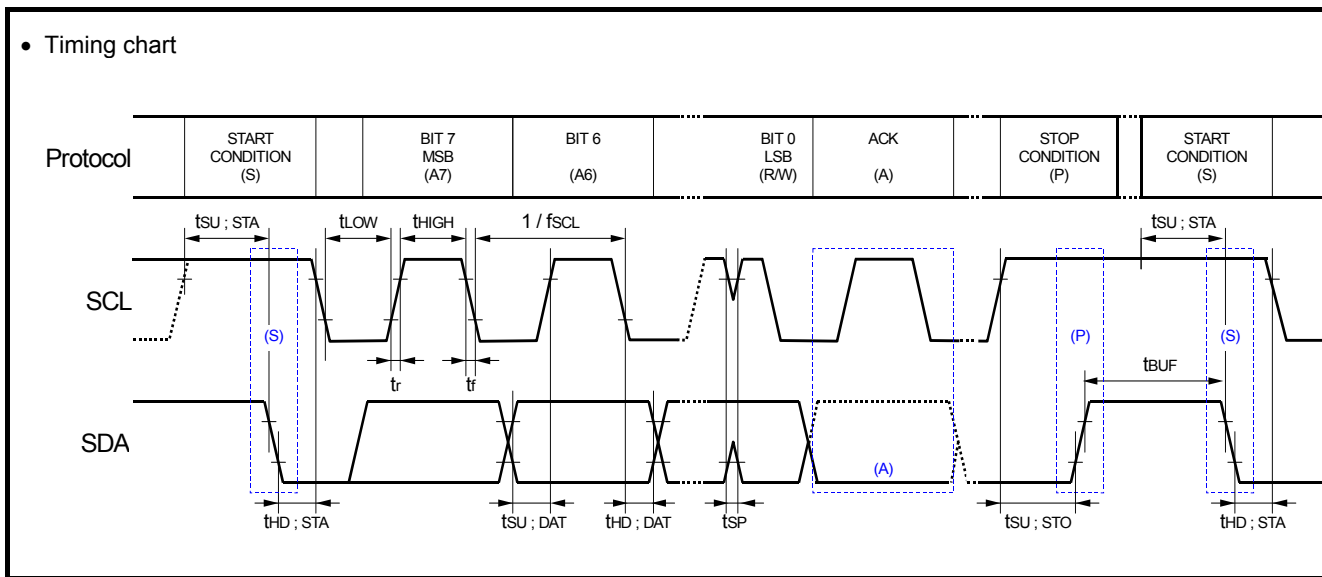

Caution:When accessing this device, all communication from transmitting the start condition to transmitting the stop condition after access should be completed within 0.95 seconds.
If such communication requires 0.95 seconds or longer, the I²C bus interface is reset by the internal bus timeout function.

8.2.2. AC characteristics (2)

*Unless otherwise specified, GND = 0 V, VDD= 1.6 V ~ 5.5 V, Ta = -40°C ~ +85°C

Item	Symbol	Condition	Min.	Typ.	Max.	Unit
FOUT symmetry (/IRQ2)	SYM	50% VIO Level	40	50	60	%

9. Matters that demand special attention on use

9.1. Instructions in the power on

9.1.1. Characteristic for the fluctuation of the power supply

*tR1 is restrictions to validate power-on reset. When cannot keep this standard, power-on reset does not work normally. It is necessary to initial setting by the software command.

Repeated ON/OFF of the power supply in short term, the power-on reset becomes unstable.
After power-OFF, keep a state of VDD=GND more than 60 seconds to validate power-on reset.
When it is impossible, please perform initial setting by the software command.

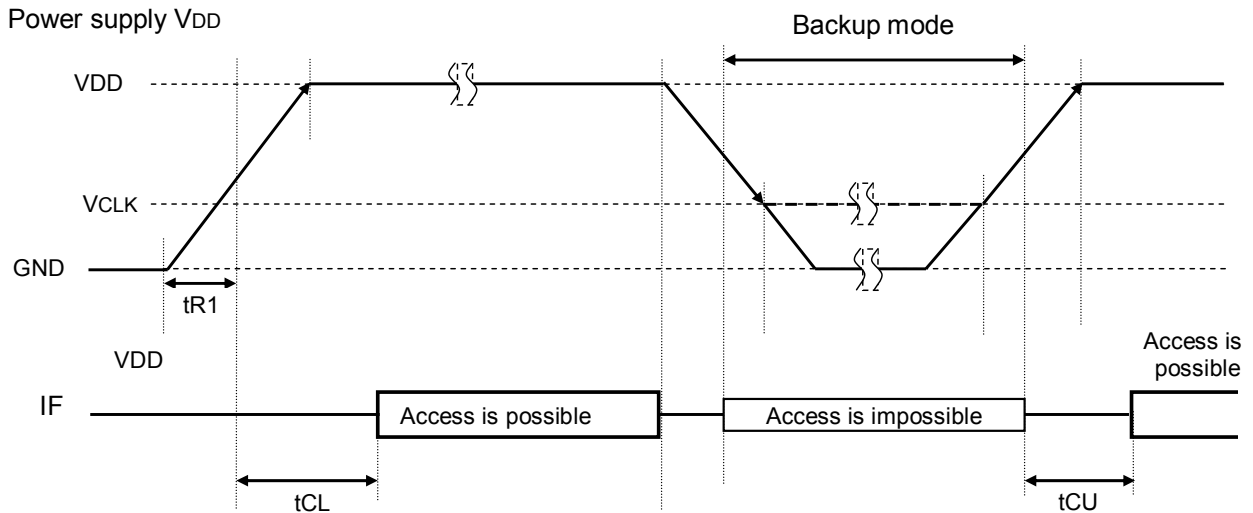

Item	Symbol	Condition	Min.	Typ.	Max.	Unit
Power supply rise time	tR1	GND – VDD	(1)*	-	(100)*	μs / V
access wait time (Initial power on)	tCL	-	(40)*	-	-	ms
access wait time (Normal power on)	tCU	-	(40)*	-	-	ms

*()Target spec.

A disappearance of the FOUT output when the voltage sharply went up and down.

For example, VDD voltage of the RX8010 is come and go between Main power and backup battery. The clock output from output pins disappears then during several milli-seconds when a sharp voltage change happens.

Please check that there is not a problem by this characteristic on your system.

An reference example of a power up and down timing without affect to FOUT.

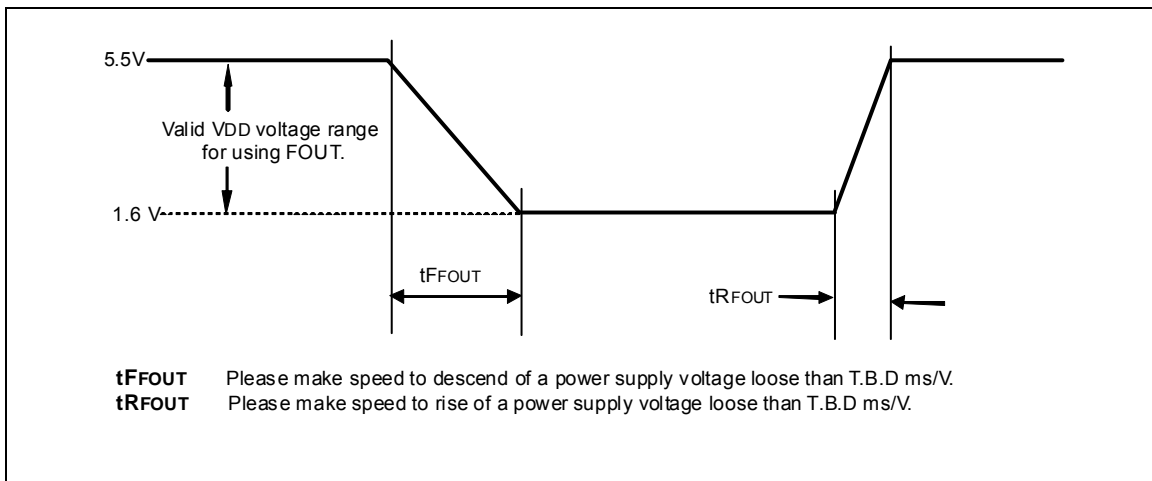

9.2. Restrictions on Access Operations During Power-on Initialization and Recovery from Backup

- RTC-register operations are linked to the internal quartz oscillator's clock signal, so normal operation is not possible if there is no internal oscillation (= oscillation is stopped).
Therefore, we recommend that the initial setting to be set during power-on initialization or backup and restore operations (i.e., when the power supply voltage is recovered after oscillation has stopped due to a voltage drop, etc.) should be "first start internal oscillation, then wait for the oscillation stabilization time (see tSTA standard) to elapse".
- Note the following caution points concerning access operations during power-on initialization or when restoring the power supply voltage from backup mode (hereafter referred to as "switching to the operating voltage").
 - 1) Before switching to the operating voltage, read the VLF-bit (which indicates the RTC error status).
 - 2) Initialization is required when the value read from the VLF-bit is "VLF = 1 (error status)".
Before initializing in response to this VLF = "1" result, we recommend first waiting for the internal oscillation stabilization time (see the tSTA standard) to elapse.

Initialization is required when the status after reading a VLF-bit value of "1" is either of the following.
 (Status 1) During power-on initialization
 (Status 2) When the clock setting is invalid, such as due to a voltage drop during backup

* Access timing during power-on initialization and when recovering the power supply voltage after a drop in the voltage used to maintain the clock

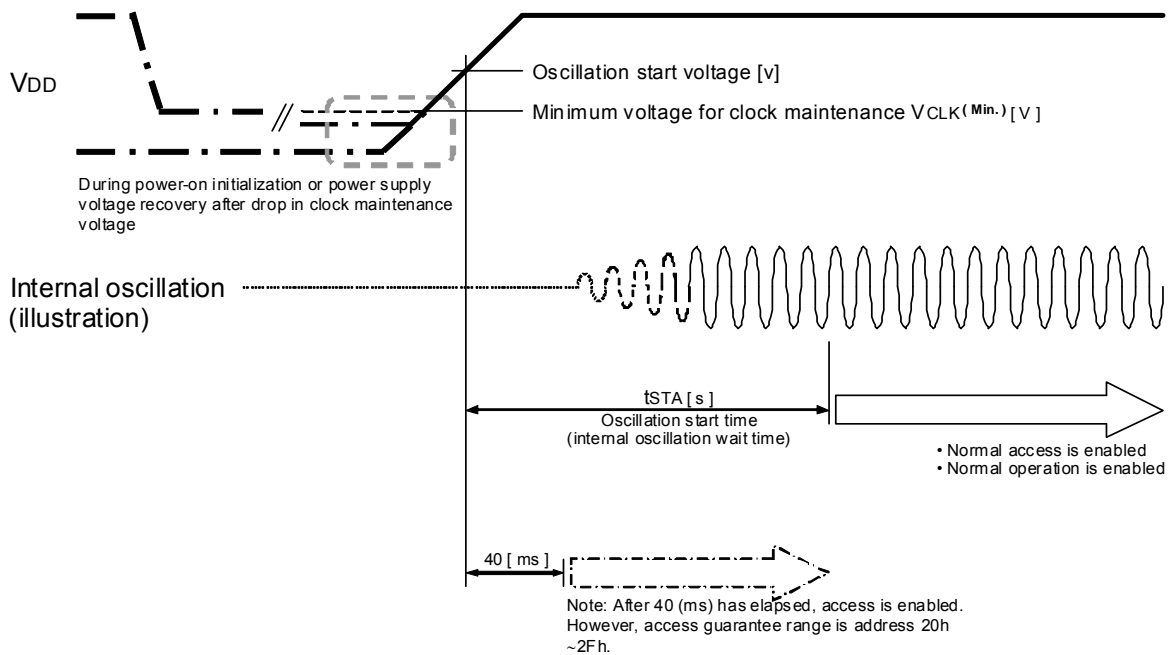

10. Reference information

10.1. Reference Data

(1) Example of frequency and temperature characteristics

$\theta_T = +25 \text{ }^\circ\text{C Typ.}$
 $\alpha = -0.035 \times 10^{-6} \text{ Typ.}$

[Finding the frequency stability]

- Frequency and temperature characteristics can be approximated using the following equations.

$$\Delta f_T = \alpha (\theta_T - \theta_X)^2$$
 - Δf_T : Frequency deviation in any temperature
 - $\alpha [1 / \text{ }^\circ\text{C}^2]$: Coefficient of secondary temperature
 $(-0.035 \pm 0.005) \times 10^{-6} / \text{ }^\circ\text{C}^2$
 - $\theta_T [\text{ }^\circ\text{C}]$: Ultimate temperature ($+25 \pm 5 \text{ }^\circ\text{C}$)
 - $\theta_X [\text{ }^\circ\text{C}]$: Any temperature
- To determine overall clock accuracy, add the frequency precision and voltage characteristics.

$$\Delta f/f = \Delta f/f_0 + \Delta f_T + \Delta f_V$$
 - $\Delta f/f$: Clock accuracy (stable frequency) in any temperature and voltage.
 - $\Delta f/f_0$: Frequency precision
 - Δf_T : Frequency deviation in any temperature.
 - Δf_V : Frequency deviation in any voltage.
- How to find the date difference

$$\text{Date Difference} = \Delta f/f \times 86400(\text{Sec})$$

* For example: $\Delta f/f = 11.574 \times 10^{-6}$ is an error of approximately 1 second/day.

11. Application notes

1) Notes on handling

This module uses a C-MOS IC to realize low power consumption. Carefully note the following cautions when handling.

(1) Static electricity

While this module has built-in circuitry designed to protect it against electrostatic discharge, the chip could still be damaged by a large discharge of static electricity. Containers used for packing and transport should be constructed of conductive materials. In addition, only soldering irons, measurement circuits, and other such devices which do not leak high voltage should be used with this module, which should also be grounded when such devices are being used.

(2) Noise

If a signal with excessive external noise is applied to the power supply or input pins, the device may malfunction or "latch up." In order to ensure stable operation, connect a filter capacitor (preferably ceramic) of greater than 0.1 μF as close as possible to the power supply pins (between VDD and GNDs). Also, avoid placing any device that generates high level of electronic noise near this module.

* Do not connect signal lines to the shaded area in the figure shown in Fig. 1 and, if possible, embed this area in a GND land.

(3) Voltage levels of input pins

When the input pins are at the mid-level, this will cause increased current consumption and a reduced noise margin, and can impair the functioning of the device. Therefore, try as much as possible to apply the voltage level close to VDD or GND.

(4) Handling of unused pins

Since the input impedance of the input pins is extremely high, operating the device with these pins in the open circuit state can lead to unstable voltage level and malfunctions due to noise. Therefore, pull-up or pull-down resistors should be provided for all unused input pins.

2) Notes on packaging

(1) Soldering heat resistance.

If the temperature within the package exceeds +260 $^{\circ}\text{C}$, the characteristics of the crystal oscillator will be degraded and it may be damaged. The reflow conditions within our reflow profile is recommended. Therefore, always check the mounting temperature and time before mounting this device. Also, check again if the mounting conditions are later changed.

* See Fig. 2 profile for our evaluation of Soldering heat resistance for reference.

(2) Mounting equipment

While this module can be used with general-purpose mounting equipment, the internal crystal oscillator may be damaged in some circumstances, depending on the equipment and conditions. Therefore, be sure to check this. In addition, if the mounting conditions are later changed, the same check should be performed again.

(3) Ultrasonic cleaning

Depending on the usage conditions, there is a possibility that the crystal oscillator will be damaged by resonance during ultrasonic cleaning. Since the conditions under which ultrasonic cleaning is carried out (the type of cleaner, power level, time, state of the inside of the cleaning vessel, etc.) vary widely, this device is not warranted against damage during ultrasonic cleaning.

(4) Mounting orientation

This device can be damaged if it is mounted in the wrong orientation. Always confirm the orientation of the device before mounting.

(5) Leakage between pins

Leakage between pins may occur if the power is turned on while the device has condensation or dirt on it. Make sure the device is dry and clean before supplying power to it.

Fig. 1 : Reference profile for our evaluation of Soldering heat resistance.

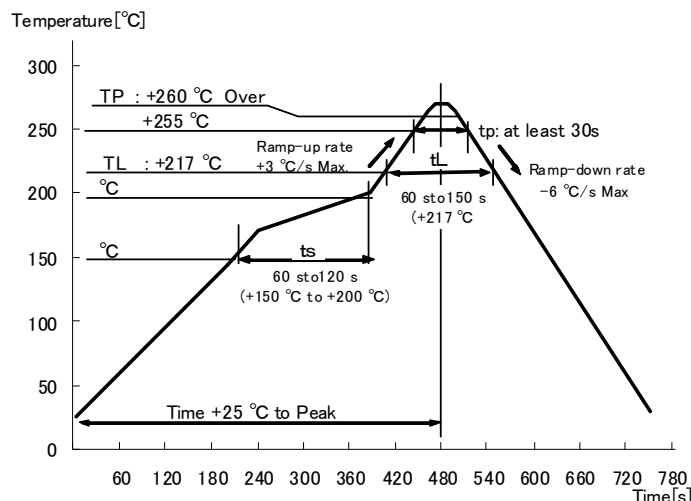

12. Overview of Functions and Description of Registers

Note:

The initialization of the register is necessary about the unused function and Reserved bit

12.1. Overview of Functions

1) Clock functions

This function is used to set and read out month, day, hour, date, minute, second, and year (last two digits) data. Any (two-digit) year that is a multiple of 4 is treated as a leap year and calculated automatically as such until the year 2099.

At the time of a communication start, the Clock & Calendar data are fixed (hold the carry operation), and it is automatically revised at the time of the communication end.

2) Fixed-cycle Timer Interrupt function

The fixed-cycle timer interrupt function generates an interrupt event periodically at any fixed cycle set between 244.14 μ s and 65535 hours.

When an interrupt event is generated, the /IRQ2 pin goes to low level ("L") and "1" is set to the TF bit to report that an event has occurred.

3) Long-Timer function

It is able to use fixed cycle timer interrupt function as Long-Timer that deals with for approx. 15 years.

4) Alarm interrupt function

The alarm interrupt function generates interrupt events for alarm settings such as date, day, hour, and minute settings. When an interrupt event occurs, the AF bit value is set to "1" and the /IRQ1 pin goes to low level to indicate that an event has occurred.

5) Time Update Interrupt Function

The time update interrupt function generates interrupt events at one-second or one-minute intervals, according to the timing of the internal clock. When an interrupt event is generated, the /IRQ1 pin goes to low level ("L") and "1" is set to the UF bit to report that an event has occurred.

6) Frequency stop detection function (VLF-bit)

This flag bit indicates the retained status of clock operations or internal data. Its value changes from "0" to "1" when data loss occurs, such as due to a supply voltage drop.

7) Clock output function

A clock with the same frequency (32.768 kHz) as the built-in crystal resonator can be output from the /IRQ1, /IRQ2 pin.

8) User RAM

RAM register is read/write accessible for any data.

12.2. Register table

Address [h]	Function	bit 7	bit 6	bit 5	bit 4	bit 3	bit 2	bit 1	bit 0
10	SEC	○	40	20	10	8	4	2	1
11	MIN	○	40	20	10	8	4	2	1
12	HOUR	○	○	20	10	8	4	2	1
13	WEEK	○	6	5	4	3	2	1	0
14	DAY	○	○	20	10	8	4	2	1
15	MONTH	○	○	○	10	8	4	2	1
16	YEAR	80	40	20	10	8	4	2	1
17	Reserved	-	-	-	-	-	-	-	-
18	MIN Alarm	AE	40	20	10	8	4	2	1
19	HOUR Alarm	AE	•	20	10	8	4	2	1
1A	WEEK Alarm	AE	6	5	4	3	2	1	0
	DAY Alarm		•	20	10	8	4	2	1
1B	Timer Counter 0	128	64	32	16	8	4	2	1
1C	Timer Counter 1	32768	16384	8192	4096	2048	1024	512	256
1D	Extension Register	FSEL1	FSEL0	USEL	TE	WADA	TSEL2	TSEL1	TSEL0
1E	Flag Register	•	•	UF	TF	AF	•	VLF	•
1F	Control Register	<u>TEST</u>	STOP	UIE	TIE	AIE	TSTP	-	-

Address [h]	Function	bit 7	bit 6	bit 5	bit 4	bit 3	bit 2	bit 1	bit 0
20 2F	RAM	User Register 128 bit (16 word x 8 bit)							

Address [h]	Function	bit 7	bit 6	bit 5	bit 4	bit 3	bit 2	bit 1	bit 0
30	Reserved	-	-	-	-	-	-	-	-
31	Reserved	○	○	○	-	-	-	-	-
32	IRQ Control	○	-	-	-	○	TMPIN	FOPIN1	FOPIN0

Note During the initial power-on (from 0 V) and if the value of the VLF bit is "1" when the VLF bit is read, be sure to initialize all registers before using them.

When doing this, be careful to avoid setting incorrect data as the date or time, as timed operations cannot be guaranteed if incorrect date or time data has been set.

- *1. During the initial power-on (from 0 V), the power-on reset function sets "1" to the VLF bit.
* Since the value of other registers is undefined at this time, be sure to reset all registers before using them.
- *2. The TEST bit are Epson test bits.
* Be sure to write "0" by initializing before using the clock module. Afterward, be sure to set "0" when writing.
* The four TEST* bits are undefined when read. Those bits should be masked after being read.
- *3. The '○' mark indicates a write-prohibited bit, which returns a "0" when read.
- *4. The '•' mark indicates a read/write-accessible RAM bit for any data.
- *5. The '-' mark is a Reserved bit. It is necessary to write in specified fixation value at the time of initialization.
- *6. User Register is a free register.

12.3. Description of registers

12.3.1. Clock and calendar counter (Reg - 10[h] ~ 16[h])

This is counter registers from a second to year.

* Please refer to [13.1 Clock calendar explanation] for the details.

12.3.2. RAM registers (Reg - 20[h] ~ 2F[h])

This RAM register is read/write accessible for any data in the range from 00 h to FF h.

12.3.3. Alarm registers (Reg - 18[h] ~ 1A[h])

The alarm interrupt function is used, along with the AE, AF, and WADA bits, to set alarms for specified date, day, hour, and minute values.

* Please refer to [13.3. Alarm Interrupt Function] for the details.

12.3.4. Timer setting and Timer counter register (Reg - 1B[h] ~ 1C[h])

This register is used to set the default (preset) value for the counter.

To use the fixed-cycle timer interrupt function, TE, TF, TIE, TSEL2, TSEL1, TSEL0, TMPIN bits are set and used. When the fixed-cycle timer interrupt function is not being used, the fixed-cycle timer control register can be used as a RAM register. In such cases, stop the fixed-cycle timer function by writing "0" to the TE and TIE bits.

* Please refer to [13.2. Fixed-cycle Timer Interrupt Function] for the details.

12.3.5. Function-related register 1 (Reg - 1D[h] ~ 1F[h])

1) FSEL1, FSEL0 bit

A combination of the FSEL1 and FSEL0 bits is used to select the frequency to be output.

The choice is possible by a combination of FSEL-bits select the frequency of clock output or inhibits the clock output.

* Please refer to [14.6. FOUT Function] for the details.

2) USEL , UF, UIE bit

This bit is used to specify either "second update" or "minute update" as the update generation timing of the time update interrupt function.

* Please refer to [14.4. Update interrupt function] for the details.

3) TE, TF, TIE, TSEL2, TSEL1, TSEL0, TSTP bit

These bits are used to control operation of the fixed-cycle timer interrupt function.

4) WADA, AF, AIE bit

These bits are used to control operation of the alarm interrupt function.

5) TEST bit

Those bits are the manufacturer's test bit. Always leave this bit value as "0" except when testing.

6) VLF bit

This flag bit indicates the retained status of clock operations or internal data. Its value changes from "0" to "1" when data loss occurs, such as due to a supply voltage drop.

* Please refer to 14.5. Frequency stop detection function] for the details.

7) STOP bit

This bit is to stop a timekeeping operation. In the case of "STOP bit = 1", working is as follows a function .

* 1) All the update of timekeeping and the calendar operation stops.

With it, an update interrupt event does not occur at an alarm interrupt and the time.

* 2) The part of the fixed-cycle timer interrupt function stops.

A count stops the source clock setting of the timer in case of "64Hz, 1Hz, 1min, 1h".

* 3) Note 3: The effect of STOP bit to FOUT functions.

When STOP = "1", 32768Hz output is possible.

But 1Hz and 1024Hz output is disabled.

12.3.6. Function-related register 2 (SPI:BANK2 Reg - 0[h] ~ 2[h] / I²C Reg - 30[h] ~ 32[h])

1) FOPIN1, FOPIN0 bit

This bit selects destination (/IRQ1 or /IRQ2) of FOUT.

2) TMPIN bit

This bit selects destination (/IRQ1 or /IRQ2) of fixed-cycle timer function.

12.3.7. Reserved bit

The '-' mark has to write in specified fixed value in the case of initialization by all means.
Writing data as follows.

Address [h]	Function	bit 7	bit 6	bit 5	bit 4	bit 3	bit 2	bit 1	bit 0
17	Reserved								
		T.B.D							
30	Reserved								
31	Reserved	○	○	○					
32	IRQ Control	○				○	○	○	○

13. How to use

13.1. Clock calendar explanation

At the time of a communication start, the Clock & Calendar data are fixed (hold the carry operation), and it is automatically revised at the time of the communication end. Therefore it recommends that the access to a clock calendar has continuous access by the auto increment function.

Setting example: Sun, 29-Feb-88 17:39:45 (leap year)

Address [h]	Function	bit 7	bit 6	bit 5	bit 4	bit 3	bit 2	bit 1	bit 0
10	SEC	0	1	0	0	0	1	0	1
11	MIN	0	0	1	1	1	0	0	1
12	HOUR	0	0	0	1	0	1	1	1
13	WEEK	0	0	0	0	0	0	0	1
14	DAY	0	0	1	0	1	0	0	1
15	MONTH	0	0	0	0	0	0	1	0
16	YEAR	1	0	0	0	1	0	0	0

* Note with caution that writing non-existent time data may interfere with normal operation of the clock counter.

13.1.1. Clock counter

1) [SEC] [MIN] register

These registers are 60-base BCD counters. These registers are incremented at the timing when carry is generated from a lower register. At the timing when the lower register changes from 59 to 00, carry is generated to the higher register and thus incremented.

When writing is performed to [SEC] register, Internal-count-down-chain less than one second (512Hz ~ 1 Hz) is cleared to 0.

2) [HOUR] register

This register is a 24-base BCD counter (24 hour format). These registers are incremented at the timing when carry is generated from a lower register.

13.1.2. Week counter

The day (of the week) is indicated by 7 bits, bit 0 to bit 6.

The day data values are counted as: Day 01h → Day 02h → Day 04h → Day 08h → Day 10h → Day 20h → Day 40h → Day 01h → Day 02h, etc.

It is incremented when carry is generated from the HOUR register. This register does not generate carry to a higher register. Since this register is not connected with the YEAR, MONTH and DAY registers, it needs to be set again with the matching day of the week if any of the YEAR, MONTH or DAY registers have been changed.

The setting example of the week register value.

Day	bit 7	bit 6	bit 5	bit 4	bit 3	bit 2	bit 1	bit 0	Data [h]
Sunday	0	0	0	0	0	0	0	1	01 h
Monday	0	0	0	0	0	0	1	0	02 h
Tuesday	0	0	0	0	0	1	0	0	04 h
Wednesday	0	0	0	0	1	0	0	0	08 h
Thursday	0	0	0	1	0	0	0	0	10 h
Friday	0	0	1	0	0	0	0	0	20 h
Saturday	0	1	0	0	0	0	0	0	40 h

* Do not set "1" to more than one day at the same time.

13.1.3. Calendar counter

1) [DAY], [MONTH] register

The DAY register is a variable (between 28-base and 31-base) BCD counter that is influenced by the month and the leap year. The MONTH register is 12-base BCD counter. when carry is generated from a lower register.

		Jan.	Feb.	Mar.	Apr.	May	June	July	Aug.	Sep.	Oct.	Nov.	Dec.
Days	Normal year	31	28	31	30	31	30	31	31	30	31	30	31
	Leap year		29										

2) [YEAR] register (Reg - 06 [h])

This register is a BCD counter for years 00 to 99.

The leap year is automatically determined, which reflects in the DAY register.

13.2. Fixed-cycle Timer Interrupt Function

The fixed-cycle timer interrupt function generates an interrupt event periodically at any fixed cycle set between 244.14 μ s and 65535 hours. This function can stop at one time and is available as a accumulative timer. After the interrupt occurs, the /IRQ status is automatically cleared .

13.2.2. Related registers for function of fixed-cycle timer interrupt function

Address [h]	Function	bit 7	bit 6	bit 5	bit 4	bit 3	bit 2	bit 1	bit 0
1B	Timer Counter 0	128	64	32	16	8	4	2	1
1C	Timer Counter 1	32768	16384	8192	4096	2048	1024	512	256
1D	Extension Register	FSEL1	FSEL0	USEL	TE	WADA	TSEL2	TSEL1	TSEL0
1E	Flag Register	•	•	UF	TF	AF	•	VLF	•
1F	Control Register	TEST	STOP	UIE	TIE	AIE	TSTP	-	-

Address [h]	Function	bit 7	bit 6	bit 5	bit 4	bit 3	bit 2	bit 1	bit 0
32	IRQ Control	○	-	-	-	○	TMPIN	FOPIN1	FOPIN0

- * Before entering operation settings, we recommend first clearing the TE bit to "0" .
- * When the fixed-cycle timer function is not being used, the fixed-cycle Timer Counter0,1 register can be used as a RAM register. In such cases, stop the fixed-cycle timer function by writing "0" to the TE and TIE bits.

1) Down counter for fixed-cycle timer (Timer Counter 1, 0)

This register is used to set the default (preset) value for the counter. Any count value from 1 (0001 h) to 65535 (FFFFh) can be set.

Be sure to write "0" to the TE bit before writing the preset value.

- * When TE=0, read out data of timer counter is default(Preset) value.
- And when TE=1, read out data of timer counter is just counting value.
- But, when access to timer counter data, counting value is not held.
- Therefore, for example, perform twice read access to obtain right data, and a way to adopt the case that two data accorded is necessary.

2) TSEL2, TSEL1, TESL0 bit

The combination of these three bits is used to set the countdown period (source clock) for this function.

TSEL2 (bit 2)	TSEL1 (bit 1)	TSEL0 (bit 0)	Source clock	Auto reset time tRTN
0	0	0	4096 Hz /Once per 244.14 μ s	122 μ s
0	0	1	64 Hz /Once per 15.625 ms	7.813 ms
0	1	0	1 Hz /Once per second	7.813 ms
0	1	1	1/60 Hz /Once per minute	7.813 ms
1	0	0	1/3600 Hz /Once per hour	7.813 ms

- *1) The /IRQ pin's auto reset time (tRTN) varies as shown above according to the source clock setting.
- *2) The first countdown shortens than a source clock.
When selected 4,096Hz / 64HZ / 1Hz as a source clock, one period of error occurs at the maximum.
When selected 1/60Hz / 1/3600Hz as a source clock, 1Hz of error occurs at the maximum.

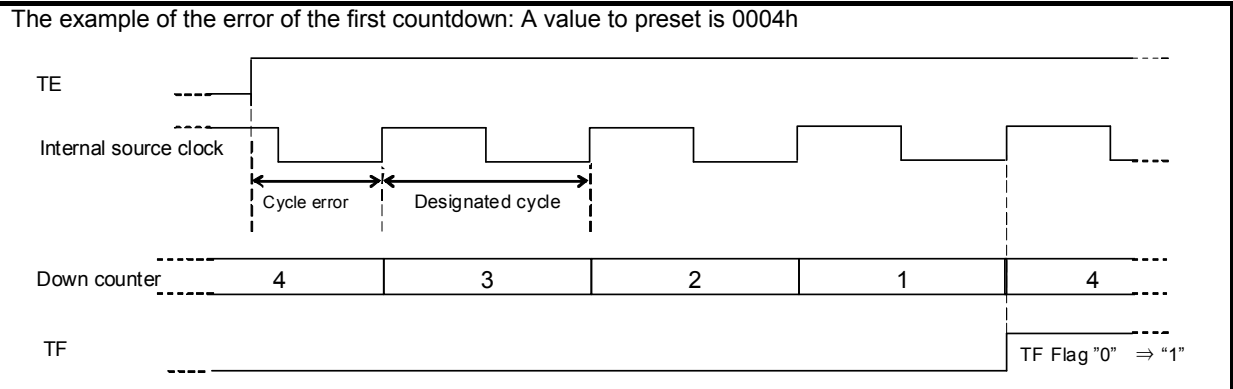

Inside counter block diagram

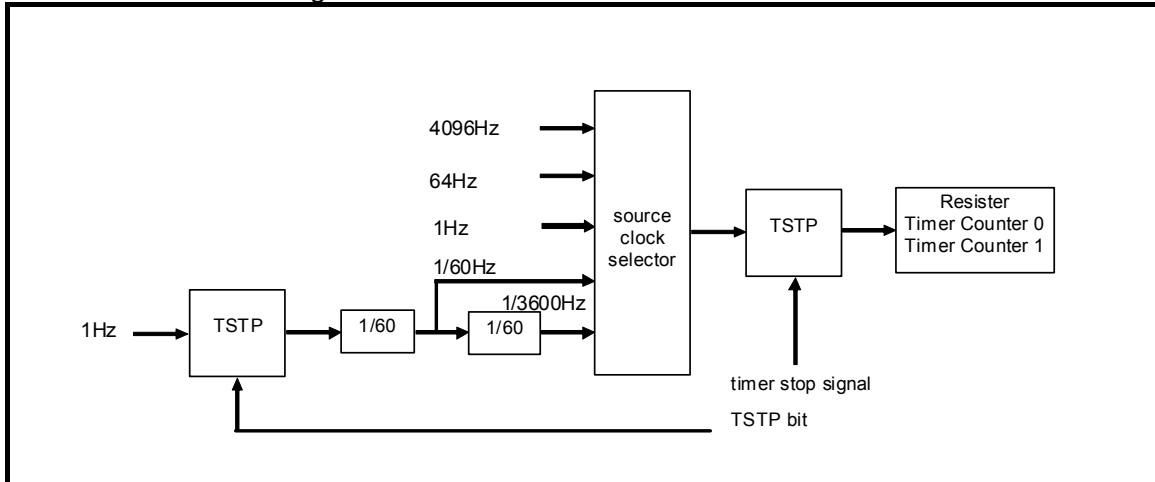

* Cannot read the count value that is lower than a selected source clock.

3) TE bit (Timer Enable)

When TE bit is "0", the default (preset) can be checked by reading this register.

TE	Data	Description
Write	0	Stops fixed-cycle timer interrupt function. * Clearing this bit to zero does not enable the /IRQ low output status to be cleared (to Hi-z).
	1	Starts fixed-cycle timer interrupt function. * The countdown that starts when the TE bit value changes from "0" to "1" always begins from the preset value.

4) TF bit (Timer Flag)

This is a flag bit that retains the result when a fixed-cycle timer interrupt event is detected.

TF	Data	Description
Write	0	The TF bit is cleared to zero to prepare for the next status detection * Clearing this bit to zero does not enable the /IRQ low output status to be cleared (to Hi-z).
	1	This bit is invalid after a "1" has been written to it.
Read	0	-
	1	Fixed-cycle timer interrupt events are detected. (Result is retained until this bit is cleared to zero.)

5) TIE bit (Timer Interrupt Enable)

This bit is used to control output of interrupt signals from the /IRQ1 or /IRQ" pin when a fixed-cycle timer interrupt event has occurred.

TIE	Data	Description
Write	0	1) When a fixed-cycle timer interrupt event occurs, an interrupt signal is not generated. 2) When a fixed-cycle timer interrupt event occurs, the interrupt signal is canceled (/IRQ status changes from low to Hi-z).
	1	When a fixed-cycle timer interrupt event occurs, an interrupt signal is generated (/IRQ status changes from Hi-z to low).

6) TSTP bit (Timer Stop)

This bit is used to stop fixed-cycle timer count down.

operation	STOP	TSTP	Description
Write	0	0	Writing a "0" to this bit cancels stop status (restarts timer count down). *The reopening value of the countdown is a stopping value
		1	Count stops.
	1	X	The count stops at the time of the setting of 64Hz, 1Hz, 1/60Hz, 1/3600Hz.

7) TMPIN bit

Select the destination of the timer interrupt output signal.(/IRQ1 or /IRQ2)

TMPIN	Data	Description
Write	0	/IRQ2 pin
	1	/IRQ1 pin

13.2.3. Fixed-cycle timer start timing

Counting down of the fixed-cycle timer value starts at the rising edge of the SCL (ACK output) signal that occurs when the TE value is changed from "0" to "1".

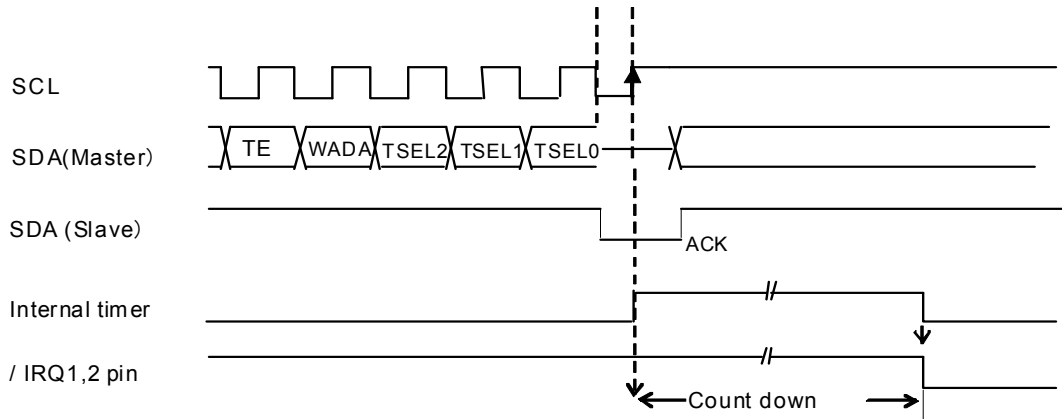

13.2.4. Fixed-cycle timer interrupt interval (example)

The combination of the source clock settings and fixed-cycle timer countdown setting sets interrupt interval, as shown in the following examples.

Timer Counter setting 1 ~ 65535	Source clock				
	4096 Hz TSEL2 = 0 TSEL1, 0 = 0, 0	64 Hz TSEL2 = 0 TSEL1, 0 = 0, 1	1 Hz TSEL2 = 0 TSEL1, 0 = 1, 0	1 / 60 Hz TSEL2 = 0 TSEL1, 0 = 1, 1	1 / 3600 Hz TSEL2 = 1 TSEL1, 0 = 0, 0
0	–	–	–	–	–
1	244.14 μs	15.625 ms	1 s	1 min	1 h
:	:	:	:	:	:
410	100.10 ms	6.406 s	410 s	410 min	410 h
:	:	:	:	:	:
3840	0.9375 s	60.000 s	3840 s	3840 min	3840 h
:	:	:	:	:	:
4096	1.0000 s	64.000 s	4096 s	4096 min	4096 h
:	:	:	:	:	:
65535	15.9998 s	1023.984 s	65535 s	65535 min	65535 h

13.2.5. Diagram of fixed-cycle timer interrupt function

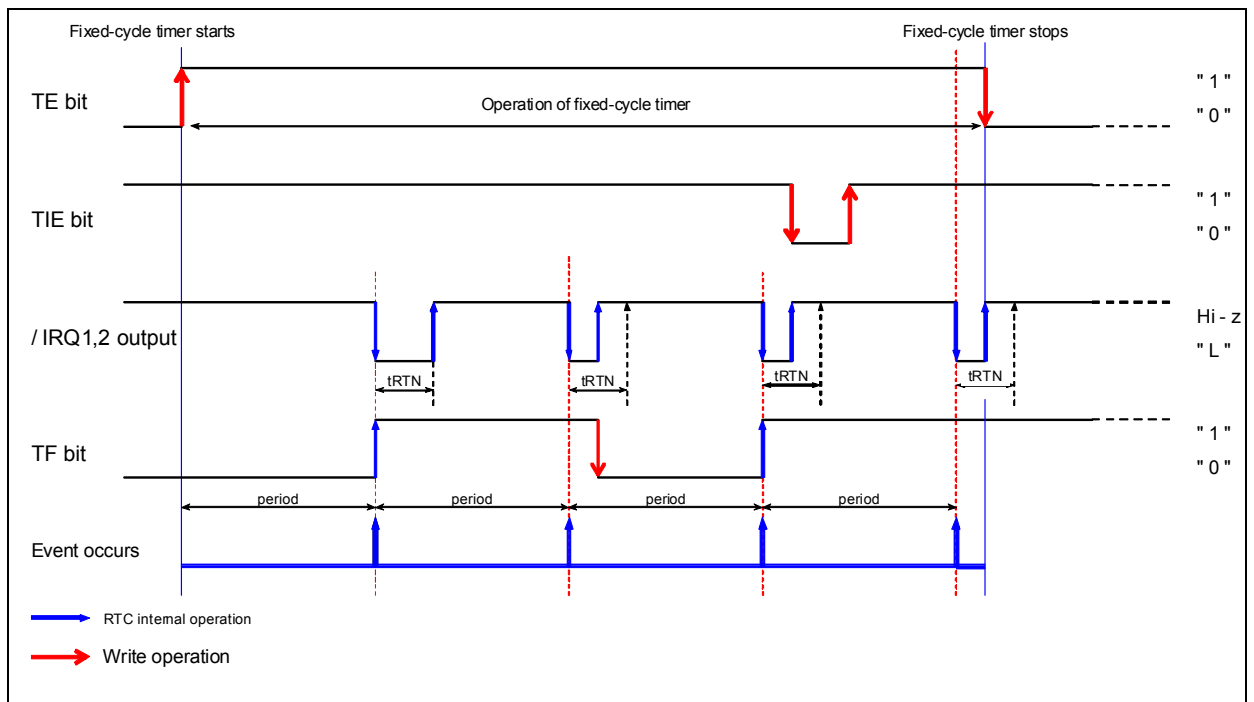

- * After the interrupt event that occurs when the count value changes from 0001h to 0000h, the counter automatically reloads the preset value and again starts to count down. (Repeated operation)
- * The count down that starts when the TE bit value changes from "0" to "1" always begins from the preset value.

13.3. Alarm Interrupt Function

The alarm interrupt function generates interrupt events for alarm settings such as date, day, hour, and minute settings.

When an interrupt event occurs, the AF bit value is set to "1" and the /IRQ1 pin goes to low level to indicate that an event has occurred. AF bit and IRQ output change after 1.46ms from alarm agreement at the maximum.

* /IRQ1="L" output when occurs alarm interruption event is not cancelled automatically unless giving intentional cancellation and /IRQ1="L" is maintained.

13.3.1. Related registers for Alarm interrupt functions.

Address [h]	Function	bit 7	bit 6	bit 5	bit 4	bit 3	bit 2	bit 1	bit 0
18	MIN Alarm	AE	40	20	10	8	4	2	1
19	HOUR Alarm	AE	•	20	10	8	4	2	1
1A	WEEK Alarm	AE	6	5	4	3	2	1	0
	DAY Alarm		•	20	10	8	4	2	1
1D	Extension Register	FSEL1	FSEL0	USEL	TE	WADA	TSEL2	TSEL1	TSEL0
1E	Flag Register	•	•	UF	TF	AF	•	VLF	•
1F	Control Register	TEST	STOP	UIE	TIE	AIE	TSTP	-	-

- * Before entering settings for operations, we recommend writing a "0" to the AIE bit to prevent hardware interrupts from occurring inadvertently while entering settings.
- * When the STOP bit value is "1" alarm interrupt events do not occur.
- * When the alarm interrupt function is not being used, the Alarm registers can be used as a RAM register. In such cases, be sure to write "0" to the AIE bit.
- * Even if use alarm register as RAM register, inside of RTC is processed as alarm setting, therefore it is able to prevent unintentional alarm occurrence (/IRQ1="L" occurrence) due to unexpected agreement with writing data and timer condition by means of setting to AIE="0".

1) Alarm registers (Reg – 18[h] to 1A[h])

In the WEEK alarm /Day alarm register (Reg - 0A), the setting selected via the WADA bit determines whether WEEK alarm data or DAY alarm data will be set. If WEEK has been selected via the WADA bit, multiple days can be set (such as Monday, Wednesday, Friday, Saturday).

- *1) The register that "1" was set to "AE" bit, doesn't compare alarm.
(Example) Write 80h (AE = "1") to the WEEK Alarm /DAY Alarm register (Reg - 0A):
Only the hour and minute settings are used as alarm comparison targets. The week and date settings are not used as alarm comparison targets.
As a result, alarm occurs if only an hour and minute accords with alarm data.
- *2) If all three AE bit values are "1" the week/date settings are ignored and an alarm interrupt event will occur once per minute.
- *3) Even if the current date/time is used as the setting, the alarm will not occur until the counter counts up to the current date/time (i.e., an alarm will occur next time, not immediately).

2) WADA bit (Week Alarm / Day Alarm Select)

The alarm interrupt function uses either "Day" or "Week" as its target. The WADA bit is used to specify either WEEK or DAY as the target for alarm interrupt events.

WADA	Data	Description
Write	0	Sets WEEK as target of alarm function
	1	Sets DAY as target of alarm function

3) AF bit (Alarm Flag)

When this flag bit value is already set to "0", occurrence of an alarm interrupt event changes it to "1". When this flag bit value is "1", its value is retained until a "0" is written to it.

AF	Data	Description
Write	0	Clearing this bit to zero enables /IRQ1 low output to be canceled (/IRQ1 remains Hi-z) when an alarm interrupt event has occurred.
	1	This bit is invalid after a "1" has been written to it.
Read	0	-
	1	Alarm interrupt events are detected. (Result is retained until this bit is cleared to zero.)

4) AIE bit (Alarm Interrupt Enable)

This bit is used to control output of interrupt signals from the /IRQ1 pin when an Alarm interrupt event has occurred.

AIE	Data	Description
Write	0	1) When an alarm interrupt event occurs, an interrupt signal is not generated or is canceled (/IRQ1 status remains Hi-z). 2) When an alarm interrupt event occurs, the interrupt signal is canceled (/IRQ1 status changes from low to Hi-z).
	1	When an alarm interrupt event occurs, an interrupt signal is generated (/IRQ1 status changes from Hi-z to low).

*The AIE bit is only output control of the /IRQ terminal. It is necessary to clear an AF flag to cancel alarm.

13.3.2. Examples of alarm settings

1) Example of alarm settings when "Day" has been specified (and WADA bit = "0")

Day is specified WADA bit = "0"	DAY Alarm								HOUR Alarm	MIN Alarm
	bit 7 AE	bit 6 S	bit 5 F	bit 4 T	bit 3 W	bit 2 T	bit 1 M	bit 0 S		
Monday through Friday, at 7:00 AM * Minute value is ignored	0	0	1	1	1	1	1	0	07 h	AE bit = 1
Every Saturday and Sunday, for 30 minutes each hour * Hour value is ignored	0	1	0	0	0	0	0	1	AE bit = 1	30 h
Every day, at 6:59 AM	1	X	X	X	X	X	X	X	18 h	59 h

X: Don't care

2) Example of alarm settings when "Day" has been specified (and WADA bit = "1")

Day is specified WADA bit = "1"	WEEK Alarm								HOUR Alarm	IN Alarm
	bit 7 AE	bit 6 •	bit 5 20	bit 4 10	bit 3 08	bit 2 04	bit 1 02	bit 0 01		
First of each month, at 7:00 AM * Minute value is ignored	0	0	0	0	0	0	0	1	07 h	AE bit = 1
15 th of each month, for 30 minutes each hour * Hour value is ignored	0	0	0	1	0	1	0	1	AE bit = 1	30 h
Every day, at 6:59 PM	1	X	X	X	X	X	X	X	18 h	59 h

X: Don't care

13.3.3. Diagram of alarm interrupt function

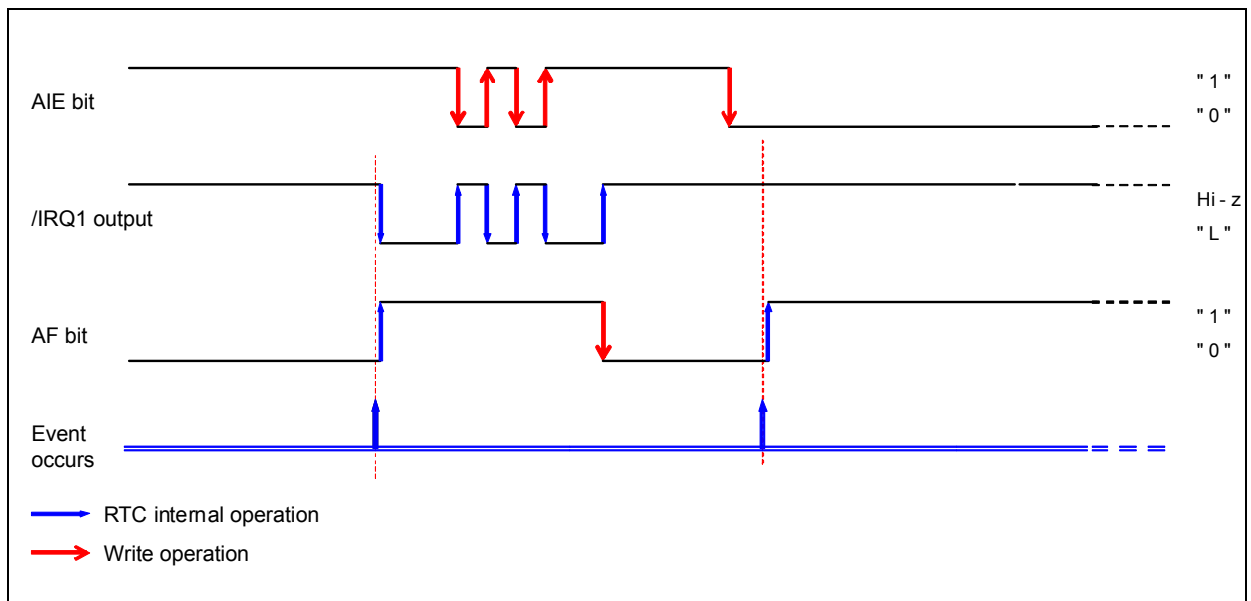

13.4. Time Update Interrupt Function

The time update interrupt function generates interrupt events at one-second or one-minute intervals, according to the timing of the internal clock. This /IRQ1 status is automatically cleared (/IRQ1 status changes from low level to Hi-z 7.813ms after the interrupt occurs).

13.4.1. Related registers for time update interrupt functions.

Address [h]	Function	bit 7	bit 6	bit 5	bit 4	bit 3	bit 2	bit 1	bit 0
1D	Extension Register	FSEL1	FSEL0	USEL	TE	WADA	TSEL2	TSEL1	TSEL0
1E	Flag Register	•	•	UF	TF	AF	•	VLF	•
1F	Control Register	TEST	STOP	UIE	TIE	AIE	TSTP	-	-

- * Before entering settings for operations, we recommend writing a "0" to the UIE bit to prevent hardware interrupts from occurring inadvertently while entering settings.
- * When the STOP bit value is "1" time update interrupt events do not occur.
- * Although the time update interrupt function cannot be fully stopped, if "0" is written to the UIE bit, the time update interrupt function can be prevented from changing the /IRQ1 pin status to low.

1) USEL bit (Update Interrupt Select)

This bit is used to select "second" update or "minute" update as the timing for generation of time update interrupt events.

USEL	Data	Description
Write	0	Selects "second update" (once per second) as the timing for generation of interrupt events
	1	Selects "minute update" (once per minute) as the timing for generation of interrupt events

2) UF bit (Update Flag)

This flag bit value changes from "0" to "1" when a time update interrupt event occurs.

UF	Data	Description
Write	0	Clearing this bit to zero enables /IRQ low output to be canceled (/IRQ remains Hi-z) when an time update interrupt event has occurred.
	1	This bit is invalid after a "1" has been written to it.
Read	0	-
	1	Time update interrupt events are detected. (The result is retained until this bit is cleared to zero.)

3) UIE bit (Update Interrupt Enable)

This bit selects whether to generate an interrupt signal or to not generate it.

UIE	Data	Description
Write / Read	0	1) Does not generate an interrupt signal. (/IRQ remains Hi-z) 2) Cancels interrupt signal triggered by time update interrupt event (/IRQ changes from low to Hi-z).
	1	When an Update interrupt event occurs, an interrupt signal is generated .

13.4.2. Time update interrupt function diagram

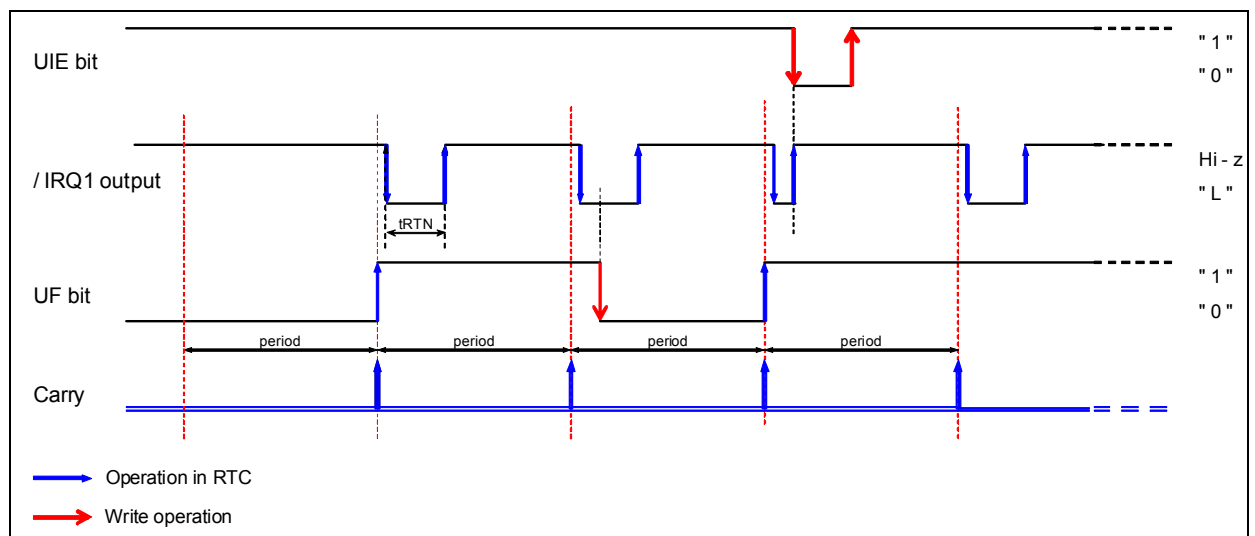

13.5. Frequency stop detection function

This flag bit indicates the retained status of clock operations or internal data. Its value changes from "0" to "1" when data loss occurs, such as due to a supply voltage drop. Once this flag bit's value is "1", its value is retained until a "0" is written to it.

During the initial power-on (from 0 V) and if the value of the VLF bit is "1" when the VLF bit is read, be sure to initialize all registers before using them.

VLF	Data	Description
Write	0	The VLF is cleared to 0, and waiting for next low voltage detection.
	1	It is impossible to write in 1 to VLF.
Read	0	RTC register data are valid.
	1	RTC register data are invalid. Should be initialized of all register data. VLF is maintained till it is cleared by zero.

13.6. FOUT function [clock output function]

The clock signal can be output via the /IRQ1, /IRQ2 pin.
When stopped the /IRQ2 pin output, the pin becomes the Hi-z.

13.6.1. FOUT control register.

Address [h]	Function	bit 7	bit 6	bit 5	bit 4	bit 3	bit 2	bit 1	bit 0
1D	Extension Register	FSEL1	FSEL0	USEL	TE	WADA	TSEL2	TSEL1	TSEL0

Address [h]	Function	bit 7	bit 6	bit 5	bit 4	bit 3	bit 2	bit 1	bit 0
32	IRQ Control	○	-	-	-	○	TMPIN	FOPIN1	FOPIN0

By a combination of FSEL1,FSEL0 , 32768Hz and 1024Hz and 1Hz and can stop the output.

13.6.2. FOUT function table.

FOUT output pin layout

FOPIN1	FOPIN0	Output pin	Output on the backup
0	0	/IRQ2	OFF(Hi-z)
0	1	/IRQ1	Enable

2) FSEL1,FSEL0 bit

FSEL1	FSEL0	output
0	0	OFF
0	1	1 Hz Output
1	0	1024 Hz Output
1	1	32768 Hz Output

X: don't care

* At the time of the initial power-on, "0" is set to FSEL1, FSEL0.

Note: The effect of STOP bit to FOUT functions.
When STOP = "1", 32768Hz output is possible.
But 1Hz and 1024Hz output is disabled.

13.7. Reading/Writing Data via the I²C Bus Interface

13.7.1. Overview of I²C-BUS

The I²C bus supports bi-directional communications via two signal lines: the SDA (data) line and SCL (clock) line. A combination of these two signals is used to transmit and receive communication start/stop signals, data transfer signals, acknowledge signals, and so on.

Both the SCL and SDA signals are held at high level whenever communications are not being performed.

The starting and stopping of communications is controlled at the rising edge or falling edge of SDA while SCL is at high level.

13.7.2. Data transfers

Data transfers are performed in 8-bit (1 byte) units once the START condition has occurred. There is no limit on the amount (bytes) of data that are transferred between the START condition and STOP condition. (However, the transfer time must be no longer than 0.95 seconds.)

13.7.3. Starting and stopping I²C bus communications

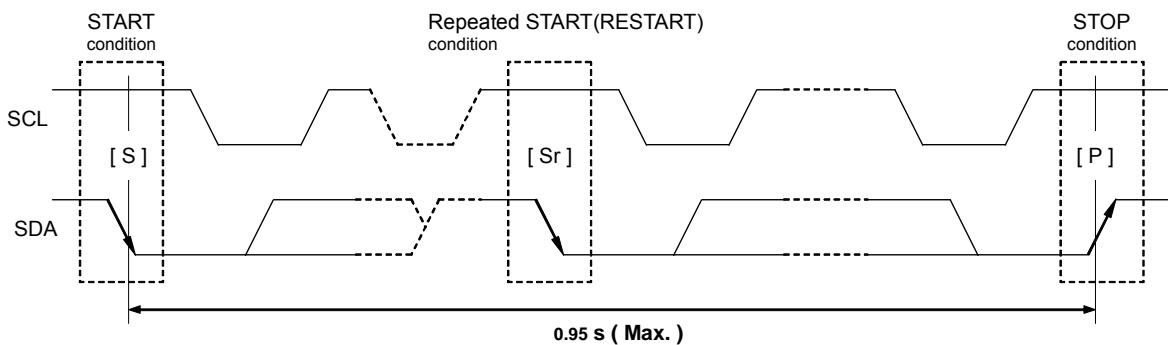

1) START condition, repeated START condition, and STOP condition

(1) START condition

- The SDA level changes from high to low while SCL is at high level.

(2) STOP condition

- This condition regulates how communications on the I²C -BUS are terminated. The SDA level changes from low to high while SCL is at high level.

(3) Repeated START condition (RESTART condition)

- In some cases, the START condition occurs between a previous START condition and the next STOP condition, in which case the second START condition is distinguished as a RESTART condition. Since the required status is the same as for the START condition, the SDA level changes from high to low while SCL is at high level.

13.7.4. Slave address

The I²C-BUS devices do not have any chip select or chip enable pins. All I²C-BUS devices are memorized with a fixed unique number in it. The chip selection on the I²C-BUS is executed, when the interface starts, the master device send the required slave address to all devices on the I²C-BUS. The receiving device only reacts for interfacing, when the required slave address is agreed with its own slave address.

During in actual data transmission, the transmitted data contains the slave address and the data with R/W (read/write) bit.

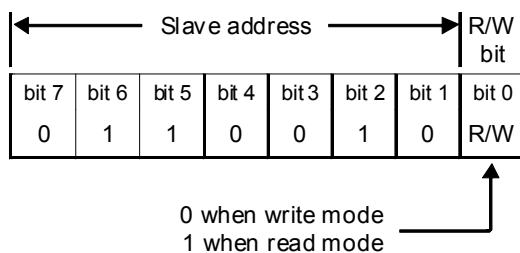

13.7.5. System configuration

All ports connected to the I²C bus must be either open drain or open collector ports in order to enable AND connections to multiple devices.

SCL and SDA are both connected to the V_{IO} line via a pull-up resistance. Consequently, SCL and SDA are both held at high level when the bus is released (when communication is not being performed).

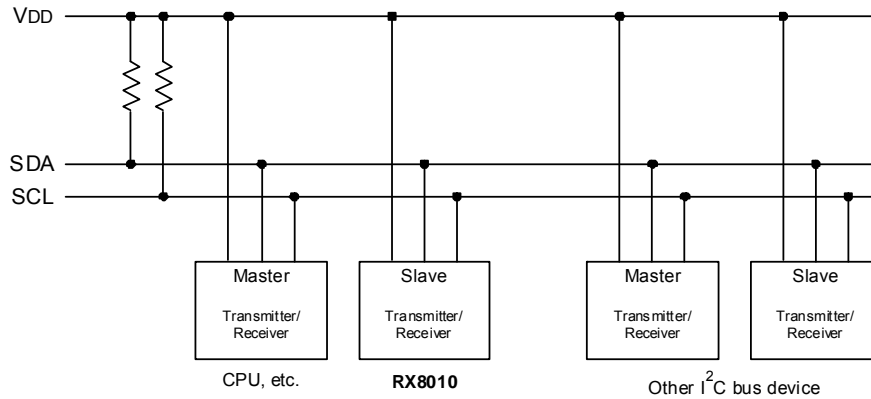

Any device that controls the data transmission and data reception is defined as a "Master".
and any device that is controlled by a master device is defined as a "Slave".

The device transmitting data is defined as a "Transmitter" and the device receiving data is defined as a receiver"

In the case of this RTC module, controllers such as a CPU are defined as master devices and the RTC module is defined as a slave device. When a device is used for both transmitting and receiving data, it is defined as either a transmitter or receiver depending on these conditions.

13.7.6. I²C bus protocol

In the following sequence descriptions, it is assumed that the CPU is the master and the RX8010 is the slave.

1) Address specification write sequence

Since the RX8010 includes an address auto increment function, once the initial address has been specified, the RX8010 increments (by one byte) the receive address each time data is transferred.

- (1) CPU transfers start condition [S].
- (2) CPU transmits the RX8010's slave address with the R/W bit set to write mode.
- (3) Check for ACK signal from RX8010.
- (4) CPU transmits write address to RX8010.
- (5) Check for ACK signal from RX8010.
- (6) CPU transfers write data to the address specified at (4) above.
- (7) Check for ACK signal from RX8010.
- (8) Repeat (6) and (7) if necessary. Addresses are automatically incremented.
- (9) CPU transfers stop condition [P].

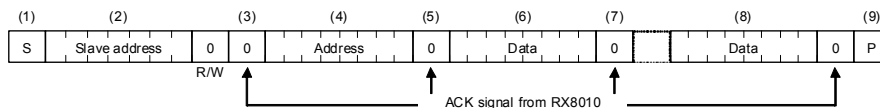

2) Address specification read sequence

After using write mode to write the address to be read, set read mode to read the actual data.

- (1) CPU transfers start condition [S].
- (2) CPU transmits the RX8010's slave address with the R/W bit set to write mode.
- (3) Check for ACK signal from RX8010.
- (4) CPU transfers address for reading from RX8010.
- (5) Check for ACK signal from RX8010.
- (6) CPU transfers RESTART condition [Sr] (in which case, CPU does not transfer a STOP condition [P]).
- (7) CPU transfers RX8010's slave address with the R/W bit set to read mode.
- (8) Check for ACK signal from RX8010 (from this point on, the CPU is the receiver and the RX8010 is the transmitter).
- (9) Data from address specified at (4) above is output by the RX8010.
- (10) CPU transfers ACK signal to RX8010.
- (11) Repeat (9) and (10) if necessary. Read addresses are automatically incremented.
- (12) CPU transfers ACK signal for "1".
- (13) CPU transfers stop condition [P].

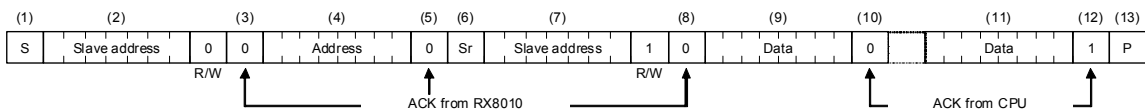

3) Read sequence when address is not specified

Once read mode has been initially set, data can be read immediately. In such cases, the address for each read operation is the previously accessed address + 1.

- (1) CPU transfers start condition [S].
- (2) CPU transmits the RX8010's slave address with the R/W bit set to read mode.
- (3) Check for ACK signal from RX8010 (from this point on, the CPU is the receiver and the RX8010 is the transmitter).
- (4) Data is output from the RX8010 to the address following the end of the previously accessed address.
- (5) CPU transfers ACK signal to RX8010.
- (6) Repeat (4) and (5) if necessary. Read addresses are automatically incremented in the RX8010.
- (7) CPU transfers ACK signal for "1".
- (8) CPU transfers stop condition [P].

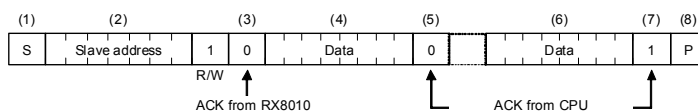

Application Manual

AMERICA

EPSON ELECTRONICS AMERICA, INC.

HEADQUARTER	214 Devcon Drive, San Jose, CA 95112, U.S.A. Phone: (1)800-228-3964 FAX :(1)408-922-0238 http://www.eea.epson.com
Atlanta Office	International Tower 229 Peachtree Street, NE Suite 510 Atlanta, GA 30303 Phone: (1)404-584-7191 (Main)
Chicago Office	1827 Walden Office Square. Suite 450 Schaumburg, IL 60173 Phone: (1)847-925-8350 Fax: (1)847 925-8965
El Segundo Office	1960 E. Grand Ave., 2nd Floor, El Segundo, CA 90245, U.S.A. Phone: (1)800-249-7730 (Toll free) : (1)310-955-5300 (Main) Fax: (1)310-955-5400

EUROPE

EPSON EUROPE ELECTRONICS GmbH

HEADQUARTER	Riesstrasse 15, 80992 Munich, Germany Phone: (49)-(0)89-14005-0 Fax: (49)-(0)89-14005-110 http://www.epson-electronics.de
-------------	---

ASIA

EPSON (China) CO., LTD.

	7F, Jinbao Building No.89 Jinbao Street Dongcheng District, Beijing, China, 100005 Phone: (86) 10-8522-1199 Fax: (86) 10-8522-1120 http://www.epson.com.cn
Shanghai Branch	High-Tech Building,900 Yishan Road Shanghai 200233,China Phone: (86) 21-5423-5577 Fax: (86) 21-5423-4677
Shenzhen Branch	12/F, Dawning Mansion,#12 Keji South Road, Hi-Tech Park,Shenzhen, China Phone: (86) 755-26993828 Fax: (86) 755-26993838

EPSON HONG KONG LTD.

Unit 715-723 7/F Trade Square, 681 Cheung Sha Wan Road, Kowloon, Hong Kong
Phone: (852) 2585-4600 Fax: (852) 2827-2152
<http://www.epson.com.hk>

EPSON TAIWAN TECHNOLOGY & TRADING LTD.

14F, No.7, Song Ren Road, Taipei 110
Phone: (886) 2-8786-6688 Fax: (886)2-8786-6660
<http://www.epson.com.tw>

EPSON SINGAPORE PTE. LTD.

No 1 HarbourFront Place, #03-02 HarbourFront Tower One, Singapore 098633.
Phone: (65)- 6586-5500 Fax: (65) 6271-3182
<http://www.epson.com.sg>

SEIKO EPSON CORPORATION KOREA Office

5F, KLI 63 Building,60 Yoido-dong, Youngdeungpo-Ku, Seoul, 150-763, Korea
Phone: (82) 2-784-6027 Fax: (82) 2-767-3677
<http://www.epson-device.co.kr>

SEIKO EPSON CORPORATION

Distributor

Electronic devices information on WWW server

<http://www5.epsondevice.com/en/quartz/index.html>